

INSTALLATION INSTRUCTIONS

Model
MP-135

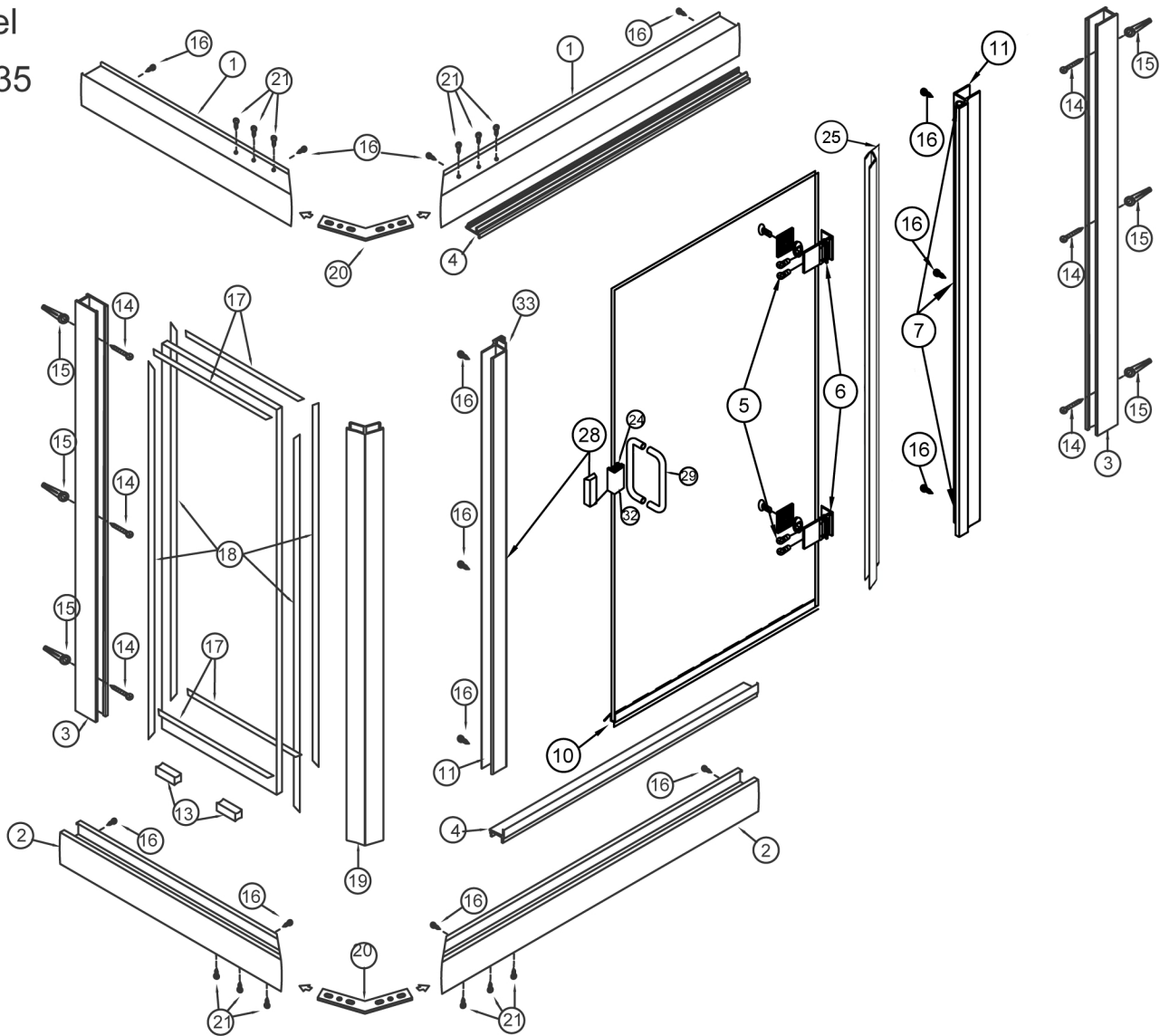

When ordering replacement parts, please provide the following information:

1. Part Number
2. Part Name
3. Model Number
4. Specify design (if any)

To install your Shower Enclosure you will need the following:

- Level
- 1/8" and 9/64" Drill Bits
- (Tile) 3/16" Masonry Bit
- Phillips Screwdriver
- Sealant
- Hack Saw

#	Description	Qty.	Part #	Picture
1	Header	2	ZSS-2101	
2	Curb	2	ZSS-2101	
3	Wall Jamb	2	ZD-1006	
4	Snap-In Filler	2	ZSS-2102	
5	#8 x 1/4SS	4		
6	Patch Hinge	2	ASD-600F	
7	Bulb Seal	3	ZV-919	
8	NA			
9	NA			
10	Bottom Rail-1/4" Poly	1	ZVP-14WS	
11	Latch Jamb	1	ZD-8004	
12	NA			
13	Glass Setting Blocks	2	ZV-902	
14	Wall Jamb Inst. Screws	6	#8x1 1/4" PH SMS	
15	Wall Anchors	6	ZV-935	
16	Installation Screw	14	#6x3/8" PH SMS	
17	Horizontal Wedge Vinyl		ZV-906	
18	Vertical Wedge Vinyl		ZV-909	
19	135° Post	1	ZSS-1105	
20	Header/Curb Bracket	2	ZH-135	
21	Header/Curb Bracket Screws	12	8x1/4" PH B	
22	NA			
23	NA			
24	Handle Gasket 1/4"		ZV-916	
25	Hinge Seal	1	P14WS	
26	NA			
27				
28	Magnet	1	MAG4013	
29	Back to Back Pull	1	ASD 8X8 T	
30	NA			
31	NA			
32	Mag U-Channel	1	MAG-4012A	
33	Strike Gasket	1	ZV-907	

Arizona Corporate Office
2801 W. Indian School Rd
Phoenix, AZ 85017
800-255-1901 PH
602-447-8208 FAX

Florida
8100-1 Westside Industrial Dr
Jacksonville, FL 32219
855-695-8899 PH
904-786-9025 FAX

Illinois
2601 Bond St #1
University Park, IL 60484
800-861-6120 PH
708-235-0729 FAX

Oregon
2057 Lars Way
Medford, OR 97501
866-773-7905 PH
541-773-7909 FAX

Colorado
3871 Revere Street
Denver, CO 80239
866-574-1766 PH
303-574-1775 FAX

Utah
2594 S. 3600 West Suite A
West Valley City, UT 84119
877-402-5007 PH
801-972-3111 FAX

ARIZONA SHOWER DOOR

Tools you will need for this install

- ✓ Exploded View drawing of shower door
- ✓ 3/16" Masonry drill bit (use 9/64" drill bit for fiberglass)
- ✓ 1/8" drill bit
- ✓ Drill
- ✓ 4' Level
- ✓ Saw (Electric Chop saw or Hacksaw)
- ✓ Side cutting pliers
- ✓ #2 Phillips drill bit
- ✓ #2 Phillips screwdriver
- ✓ Tape Measure
- ✓ Pencil or Pen
- ✓ Caulking Gun
- ✓ 1-Tube of 100% Clear Silicone (no latex!)
- ✓ Vacuum Cleaner or Brush for clean up
- ✓ Glass Cleaner and Paper Towels
- ✓ Rubber Mallet
- ✓ File

Installation Instructions for

Model MP-135

Note: These instructions will refer to the item #'s in the Exploded View drawing. For example, #1, #2, #3 etc...
Please read through **all** of the instructions to get an over-view **before** you install the shower door.

1) Find the centerline of where the unit will be installed. This will usually be the center of the curb of the shower pan. Place a mark $1/2''$ inch to the outside of centerline at each end of the curb where it meets the wall and at the corner. These marks will represent the outside of the ZSS-2101 Curbs (item #2 in exploded view) **(A)**. Use the centerline measurements that were given at the time of order to figure your ZSS-2101 sizes. Take the centerline measurements and add $1/4''$ to get the outside dimension of each ZSS-2101. Measure from the **outside** edge of the mitered corner, along the **outside** of the ZSS-2101 to the correct dimension and cut to size. Repeat this procedure for the other ZSS-2101 Curb **(B)**. Lay the curbs on drop cloth or carpet to prevent from scratching them. Assemble the curbs on the floor using the ZH135 135° degree Header Bracket (#20) and the #8X $1/4''$ Header Curb Bracket Screws (#21). As the curbs are lying open end down, place the ZH135 bracket onto the corners and align the miters, corner bracket, and holes. Fasten the corners together with the #8x $1/4''$

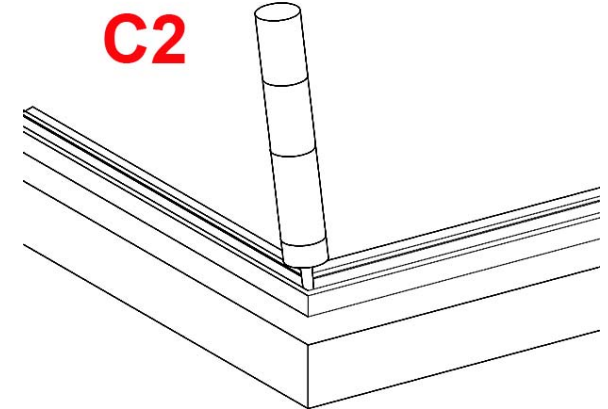
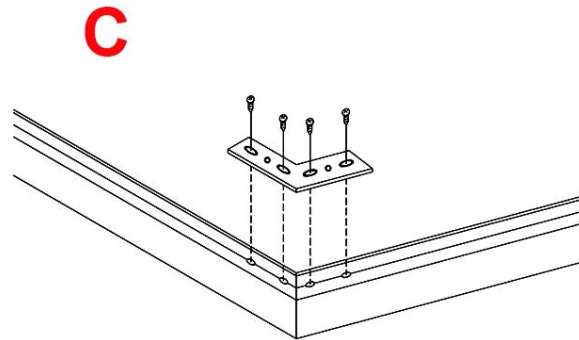
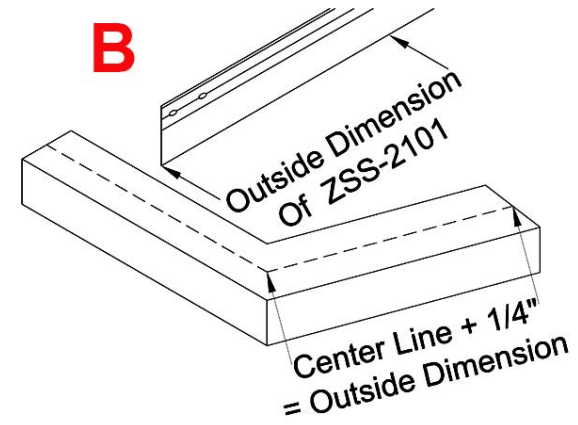
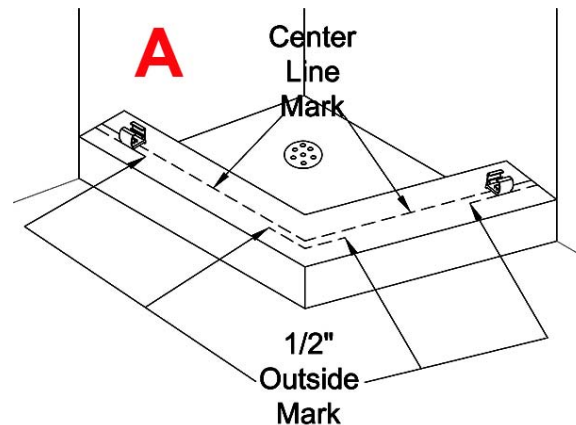

Screws. Now place the assembled Curb pieces in the position laid out on the shower curb corresponding to the marks that you made. Make sure to fill the corners where the screws were inserted and the ends with silicone so as to seal any gaps that might leak but do this after the wall jams are installed **(C)**.

2) Place a Wall Jamb ZD-1006 (#3) against the wall and down into the Curb. Use a level to position the jamb plumb, then mark the installation holes with a pen or pencil. Repeat this procedure for the other jamb **(D)**. Now drill the 6 holes with a 3/16" masonry bit (9/64" for fiberglass, & without anchors). Then insert the 6)-ZV935 screw anchors (#15) in the holes. Fasten the ZD-1006 wall jams in place using the #8X1-1/4 Phillips Pan Head screws provided (#14). Fill the corner inside the ZSS-2101 to protect against water leaks **(E)**.

3) Place two Setting Blocks ZV902 (#13) into the Curb on the side where your panel will be. Insert the Glass into the ZSS-2101 Curb and the ZD-1006 Wall Jamb. Insert the 135 Post ZSS-1105 (#19) into the Curb and onto the edge of the glass **(F)**.

4) Plumb your ZSS-1105 135° corner post. Measure from the wall above the ZD-1006 Wall Jamb over the glass to the outside and to the center of the ZSS-1105 135° post. Add 1/8" to the measurement then mark the header at that dimension and cut. Repeat the procedure for the other ZSS-2101 Header **(G)**.

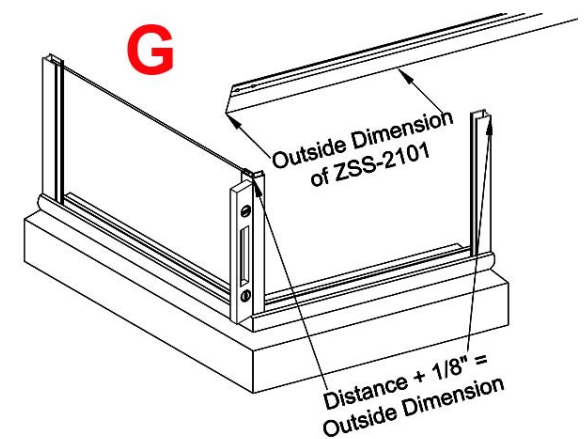
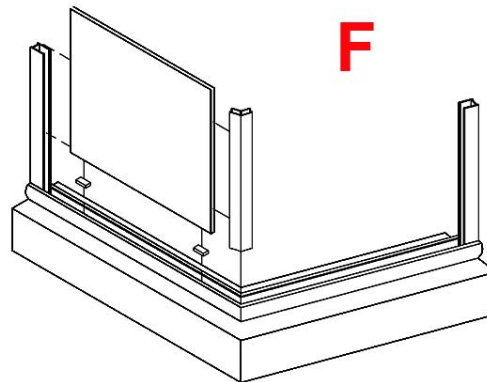
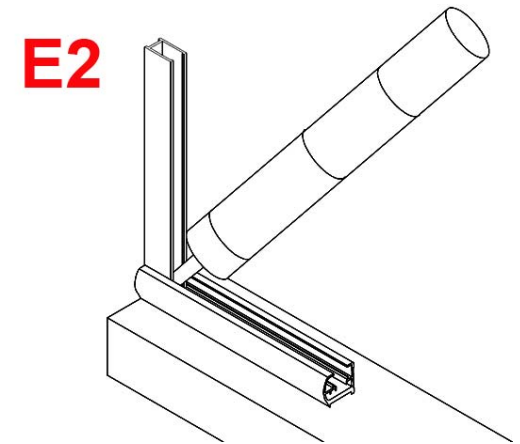
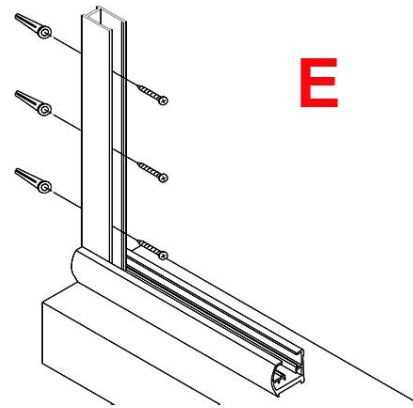
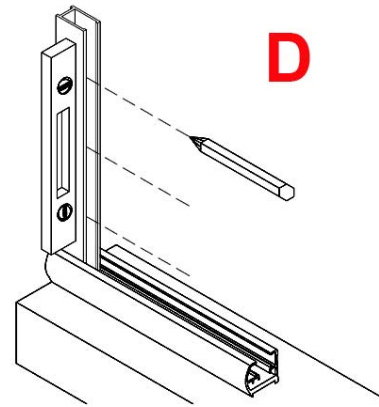

5) Assemble the Header on the floor (like previously on the Curb) using the ZH135 135 degree Header Bracket (#20) and the #8X1/4" Header Curb Bracket Screws (#21). As the headers are lying open end down, place the ZH135 Bracket onto the corner and align the miters, corner bracket, and holes. Fasten the corner together with the #8x1/4" screws (refer to **(C)**). Now place the assembled header pieces over and down onto the vertical posts. Attach the Header to the Wall Jambs and 135 Post from the inside using a 1/8" drill bit to drill through the header and into the wall jambs and 135 Post being **extremely careful** not to drill into the glass. Secure with the #6X3/8" screws (#16) **(H)**. Insert the ZV909 Wedge Vinyl (#18) into the jambs on both sides of the glass. A block of wood will help push the vinyl in. Slightly wet the vinyl with water to ease install. The flat side goes against the glass. Notice the locking groove **(I)**. Insert the ZV906 Horizontal Wedge Vinyl into the header and curb (#17) in between the metal and glass without stretching it, both inside and out, top and bottom. Notice the locking groove **(J)**.

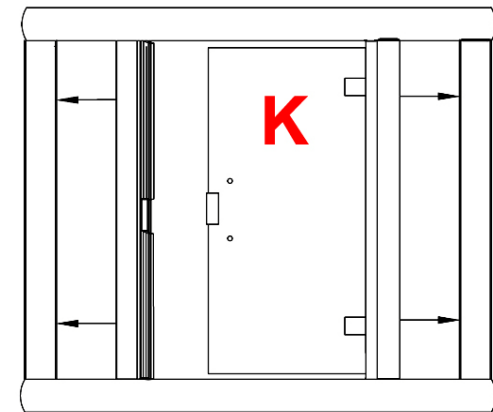
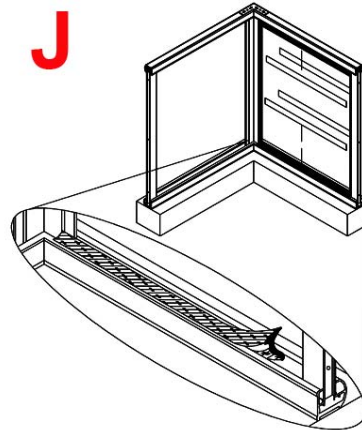
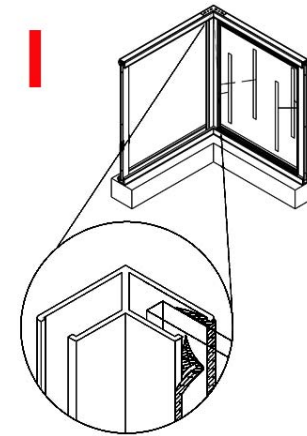
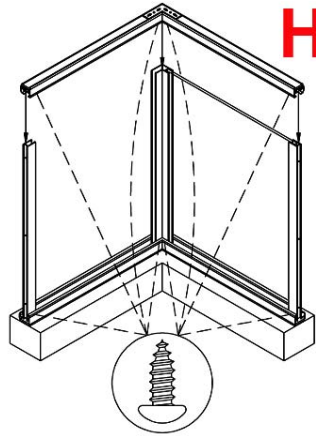

6) Hang the door. Slide the ZD8004 "Magnetic Latch Jamb" (#2) over the latch side wall jamb. **(Note:** There are two ZD8004's. The "Magnetic Latch Jamb" is **not** attached to the Door Glass.) Next install the door by sliding the ZD8004 "Door Hinge Jamb" (#2) over the hinge side wall jamb. Do not fasten the door at this point. **Note:** (It will be helpful to have an assistant at this point to adjust and hold the door in place from the outside while you drill and fasten the latch jamb and the hinge jamb from the inside) **(K)**. First you will need to attach the MAG4012

(#4). by placing the ZV 916 for ¼" glass (#23) over the edge of the glass then tapping the MAG4012 over the gasket and on to the glass with a rubber mallet aligning it to the magnet on the latch jamb.(See (N) for help). Square up the door and align the edge of the door glass parallel with the latch jamb leaving a 1/16" gap between the ZD8004 and the MAG4012 (L). Attach the door by drilling the six holes on the inside of the unit where the jambs are pre-drilled using a 1/8" drill bit and secure with the 6-#6X3/8" Pan Head screws (#16) (M)

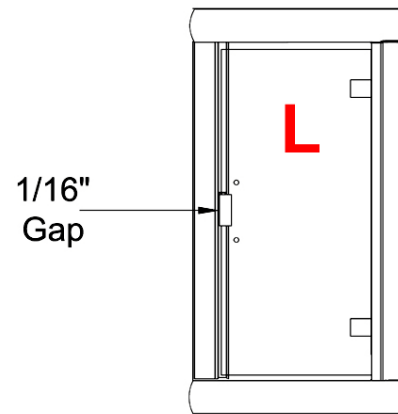

7) Attach the ASD 8X8 Handle (#29). Take the two stud head mounting screws and sleeve one clear washer on each screw. Next, insert the clear grommets into the holes in the door. From the outside of the door, push the thread of the screws through the grommets in the holes in the glass. On the inside of the door, sleeve a clear washer onto the screws. Take the pull that has the threaded hole in the end and begin to thread the top screw into it and then the bottom screw. Tighten the stud head screws down with a screwdriver (not a drill). This pull will be on the inside of the door. Place the remaining pull, with the large holes and set screw, onto the stud heads of the screws. Tighten the set screws with Allen wrench provided (N).

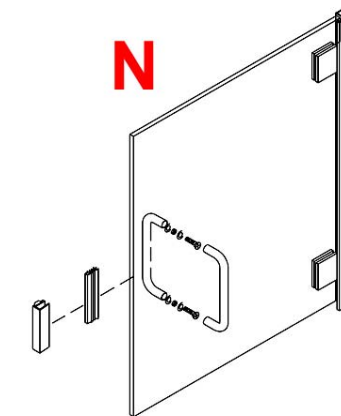
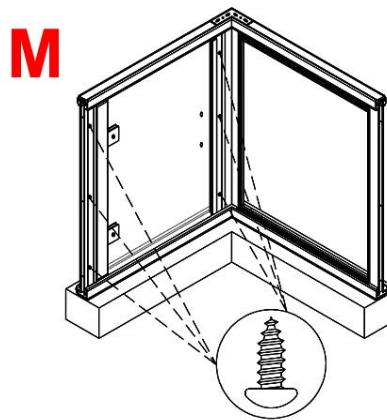

8) Now you need to cut the Snap In Filler ZSS2102 (#4). There are a number of ways to calculate the size of the ZSS2102. This simple method will work for standard width as well as custom. Measure the distance in-between the ZD8004 "Magnetic Latch Jamb" and the ZD8004 "Door Hinge Jamb". This will be the size of your ZSS2102. Cut to that Dimension (O).

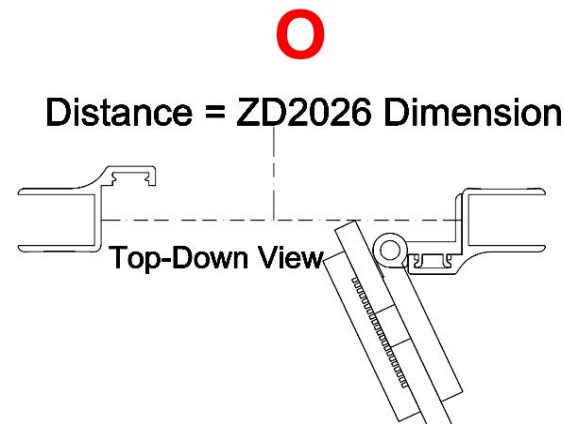

9) Snap the fillers into the 2101's top and bottom. There is a small lip on the filler. This faces to the outside of the unit **(P)**.

10) Cut the Bottom Poly Rail (ZVP-316WS for 3/16" glass, ZVP-14WS for 1/4" glass) then push over the bottom edge of the glass. Run a cap bead of silicone on the inside where the glass and poly meet to prevent water seeping down into the sweep between the glass and poly **(Q)**.

11) Run a bead of silicone on the gap between the metal and the shower surface inside and out around the entire unit. Fill all joints and gaps where metal meets metal and fill with a fine bead **(R)**.

