

ARIZONA | SHOWER DOOR

HG-I-HP-38

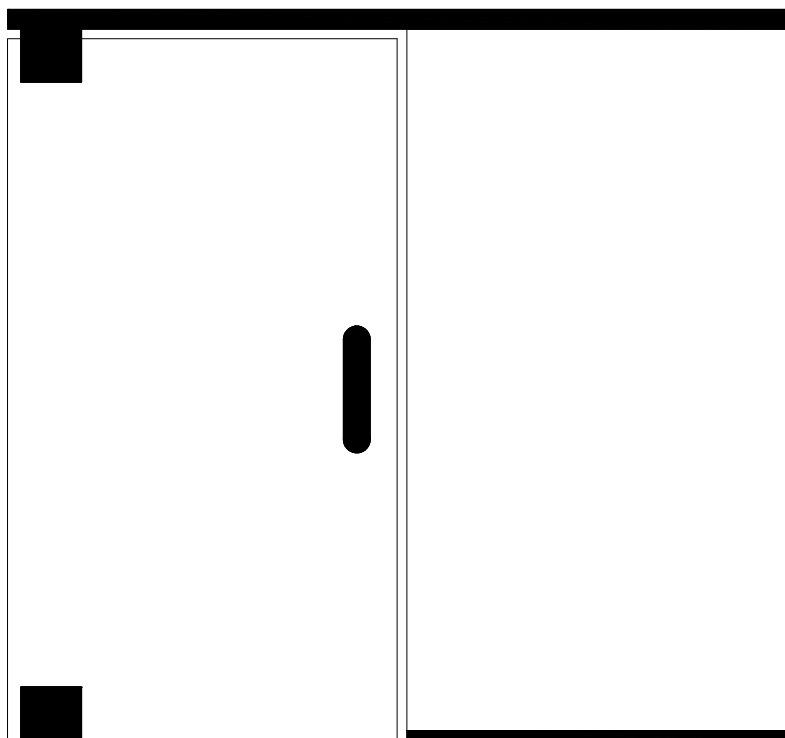

Please read instructions completely before proceeding to get an overview of the installation.

Brief Outline of Installation Procedures

- A) Prior measure of opening with centerline dimensions. For necessary accuracy a 2', 4', and 6' level should be used on appropriate surfaces as heavy frameless units are designed to be installed level and plumb.(Fig.A)

Plumb and Centerline Example

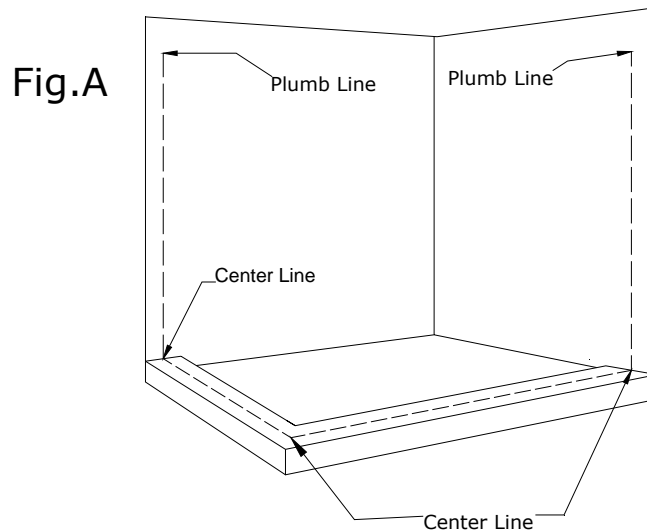

- B) Mark centerline plumb line for BWB2 Brass Wall Mount header clamp location
- C) Preparing u-channel for installation i.e. cutting, drilling
- D) Installing channel
- E) Setting panels
- F) Cutting, Assembling, and Installing Header
- G) Mounting Hinges
- H) Setting door
- I) Mount door pull
- J) Clean glass
- K) Install seals and adjust door if needed
- L) Apply silicone

BWB2 plumb line

On both walls, take a level and make a pencil line up the wall corresponding to the centerline of the glass. Then place a mark on the center line, 1/4" down from the top

of where the header will finish (the overall height of the unit)(Fig.B).

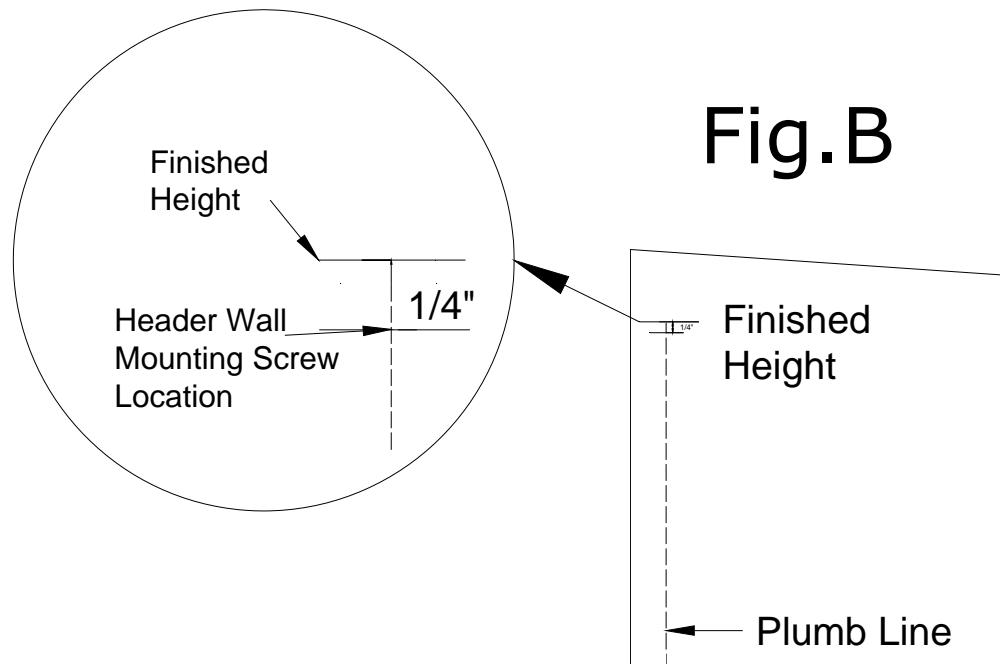

This will be the location of the wall mounting screw(Fig.C).

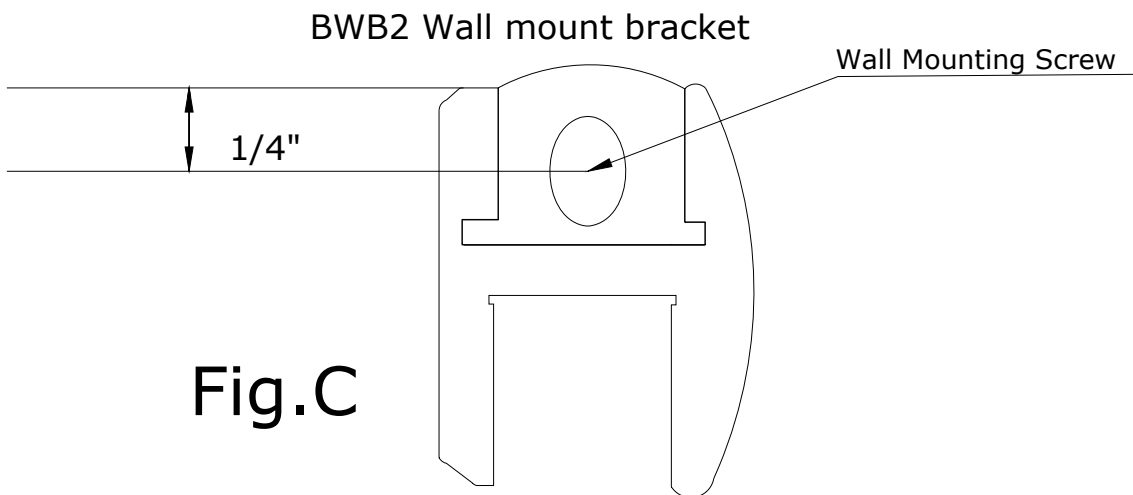

You may drill these now or wait until glass is set to test fit header and hole locations. Drilling instructions are in the cutting, assembling, and installing header section.

Cutting U-channel

Using the center line dimensions used to figure glass sizes you can figure u-channel cut sizes.

Use the following formulas to get cut sizes.(Fig.D)

Door Inline Channel Application

Fig.D

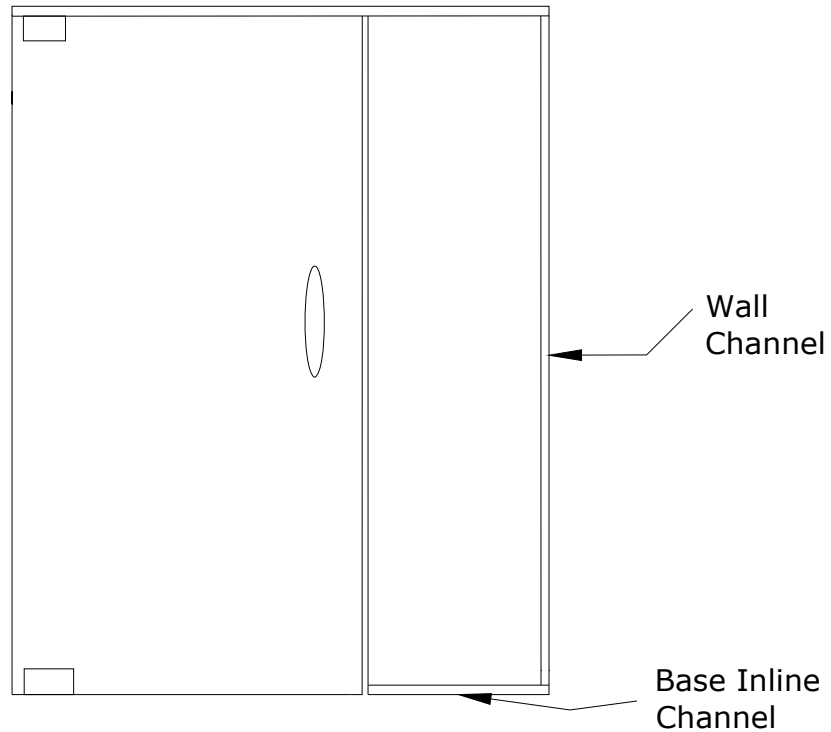

Base inline channel: bottom dimension of inline panel + $5/16''$

Wall channel: actual height of glass - $3/16''$

*Oil Rubbed Bronze u-channel does not fit inside the header. The formula for ORB is:
Overall height of Unit - $2''$

It will be helpful to preserve the marks from the time of the measure to the day of the install so the installer has reference marks.

Installation of Channel

1) Drill **base inline channel** for weep holes,(Fig.E) as close to the bottom as possible, on the inside wall of the channel with a $3/16''$ drill bit approximately 6 inches in from each end. Two holes are sufficient. If channel is under 12" only one hole is necessary.

Weep Hole Location

Fig.E

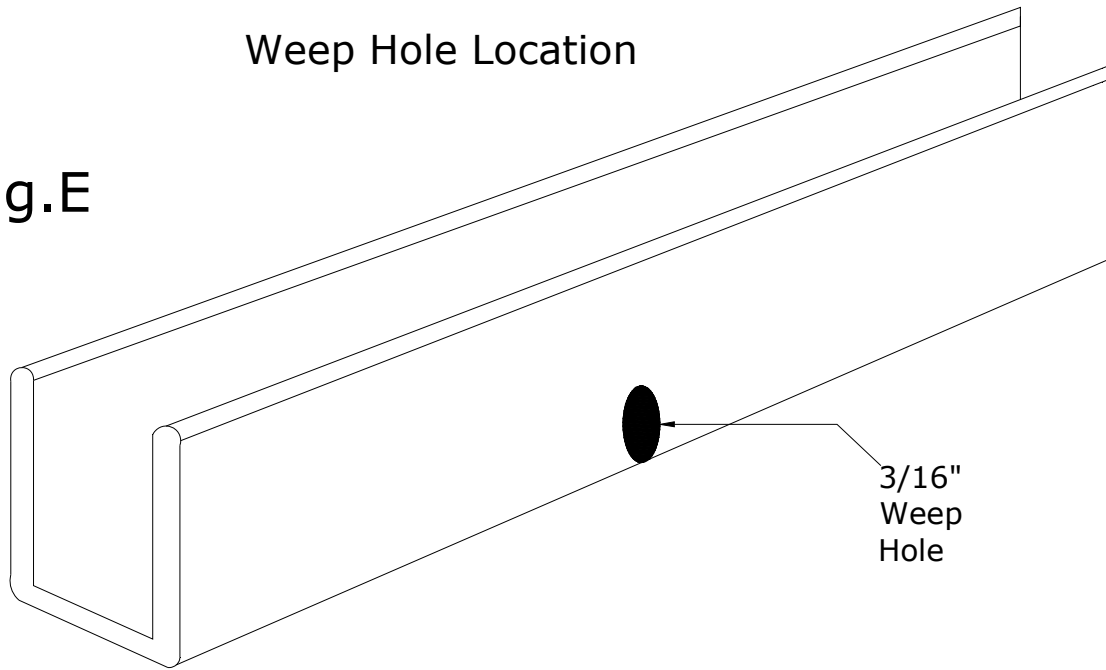

2) Drill bottoms of all channels with 3/16" holes approximately 12" apart for mounting to surface.

3) Align all channels based on the centerline marks that were made at the time of measure. Wall channel will set on top of base channel.(Fig.F) Mark the holes to be drilled. Mark the holes while you hold the vertical channel plumb with a level, or use blue tape to hold it plumb.

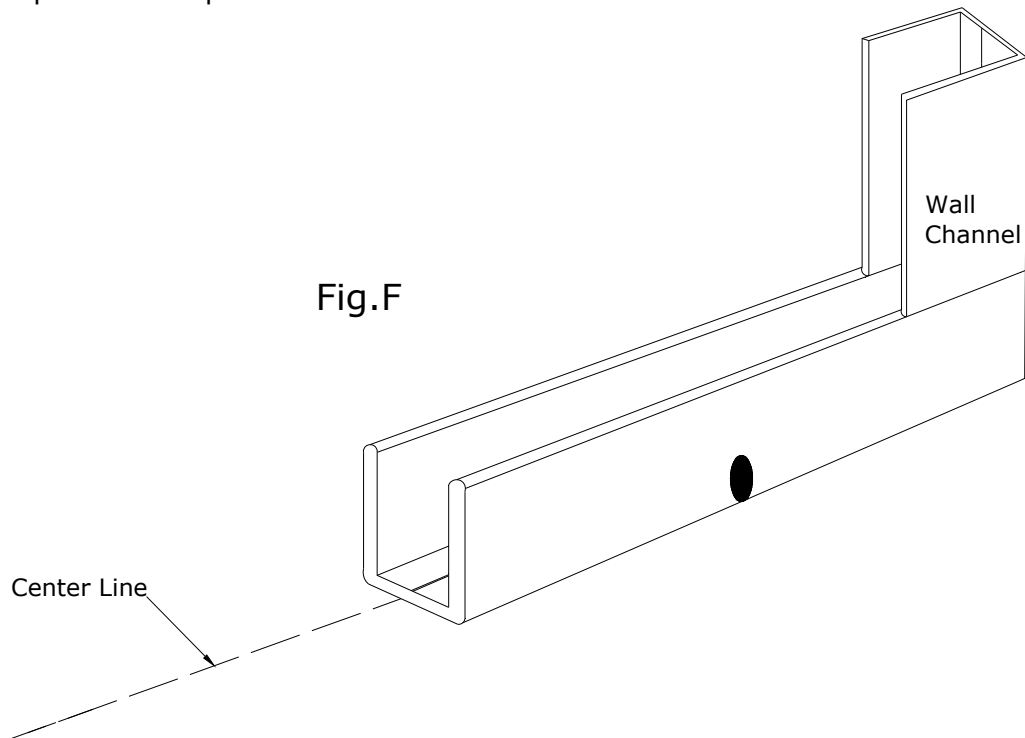

4) After holes are marked, drill holes with 3/16" masonry drill bit. Apply silicone in holes on horizontal surface. Insert 3/16" plug anchors in all holes.

5) Secure channel with #8x1 flathead screws and drill. Remember that vertical channels will sit on horizontal channels where they meet. Apply blob of silicone over screw heads in horizontal channels and in all corners and seams.

Setting Glass Panels

1) Place 1/4" setting blocks in channels, one on each end where glass will sit.

2) Inline Panel: Using a glaziers suction cup, set inline panel over base channel and lower down into the channel and down onto setting blocks being very careful not to set glass on the metal.(Fig.G) Use a level to check plumb and level of panel. If outages were accurately accounted for in the measure, **the panel should be plumb and level**. Move panel into wall channel with exposed polished edge on glass flush with open end of channel.

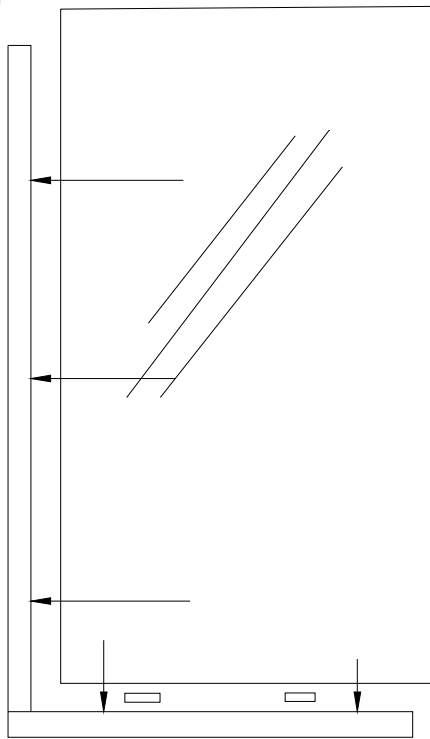

Fig.G

Set panel in wall channel first,
then down into bottom channel

Cutting Assembling and Installing Header

(1) Measure the distance wall to wall over the top of the glass. Cut your header to this length.

2) Now you can place the 2) BWB2 Brass Wall Brackets into the ends of the header and position them flush to the end of the header. The hole in the end of the bracket will face the wall that you are attaching your header to. With the brackets positioned correctly, firmly tighten the Allen set screws in the bracket until they are secured.

3) Installing Header: Now that the header has been cut and assembled, it can be installed. To test fit the header, use two 1" strips of the header vinyl and place on

the top of the panel. Place the header down on top of the glass to check the fit. Make any necessary adjustments. Header should be level and allow clearance for the door glass including the 7/16" setting blocks. The holes in the BWB2 should match the marks you made earlier for the wall mounting screws. Remove the header. Remove the panel. (You have the option of drilling the holes when they were marked earlier in the process, when the BWB2 plumb lines were made and the glass had not been set yet). Drill with a 3/16" masonry bit. Follow with a 1/4" masonry bit and insert a 1/4" wall anchor flush to installation surface. Then put a full length strip of clear vinyl on top of the glass and install the header. Do not push header down too far or the vinyl will fold up into the header and then you will have to start over. The header will slide down approximately 3/8" over the top of the glass. Secure with the 2" screws provided.

Mounting Hinges

Mounting Top Hinge: (Fig.J)

Determine which side you want to hinge from. If the hinge is on the panel side then measure over 2" (presuming it is plumb) then make a pencil mark on the outside of the header. If the hinge is on the wall side then measure over 2" (+ or - wall outage) from the wall then make a mark on the outside of the header with a pencil. This is the location of where you will drill a 1/4" hole vertically through the center of the header cross web. Remove the base plate from one of the hinges using a #2 Phillips screwdriver, then, insert the square base of the pin into the Header Adapter Block. With hinge inserted, slip the Adapter Block up into the header. While holding the hinge in place secure it from above with the shorter of the two pan head screws that came with the Header Adapter Block. This will take a #3 Phillips head screwdriver. (Disregard the long notch in the Adapter Block as it is for a clip not used in this application.) Measure the open channel space above the door, cut and install the Snap In Filler Insert.

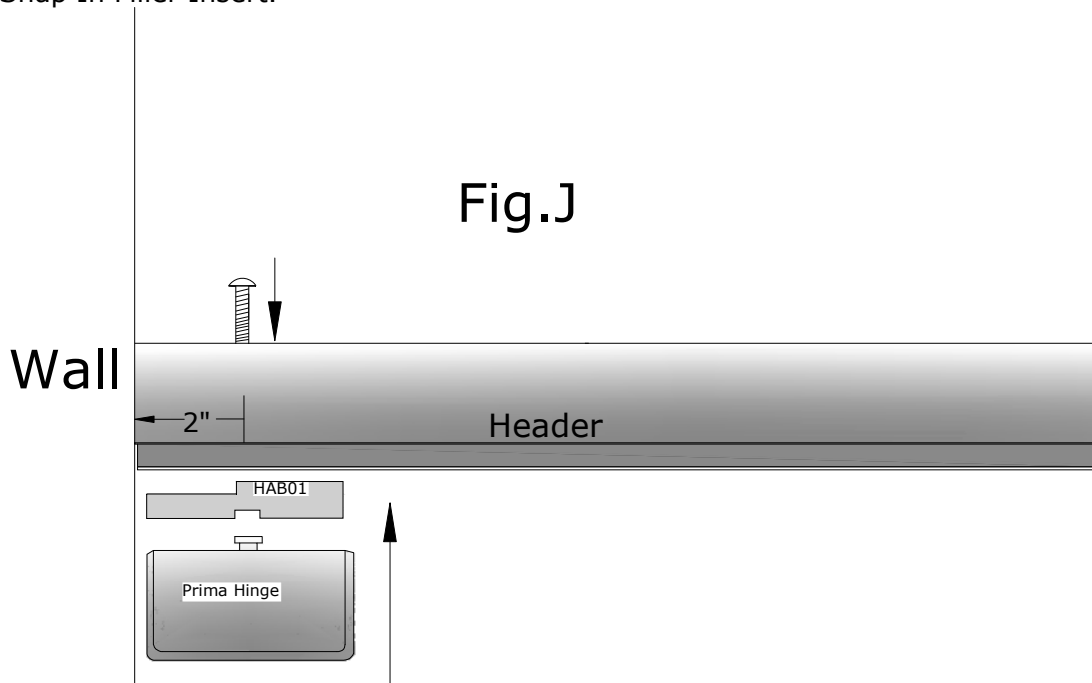

Mounting Bottom Hinge: (Fig.K) Measure 2" over from the inline panel or the wall, depending on your application, on the centerline. This will be the center of the pin. Holding the back plate of the hinge, turn the hinge 90* so you can mark the 2 hinge holes on the curb (or use the back plate that was removed from the top hinge, as your template). Mark the holes. Drill holes in curb using a 3/16" masonry drill bit. After drilling the two holes, follow with a 1/4" masonry bit. Insert 1/4" wall anchors. Cut anchors flush to tile surface if they do not fully insert. Secure hinge with the screws provided.

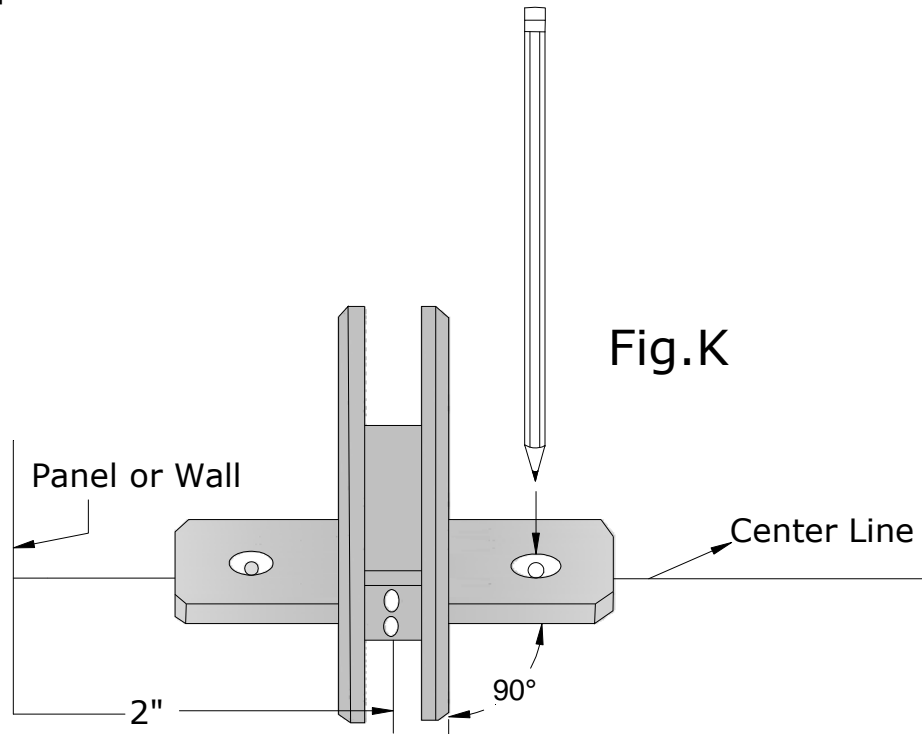

Setting Door

This will take two people

Installing Door: The glass and gaskets should be free of grime, grease, oils or anything else that would prevent the hinge and gasket from making good contact with glass. Use glass cleaner to remove these things. Remove the cover plates and screws from the hinges. Apply the gaskets to both sides of the door around the hinge cutouts. Apply light pressure so they will stay in place. Place 2) 7/16" setting blocks on the curb to give the proper clearance for the sweep.

Setting Blocks For Door Example

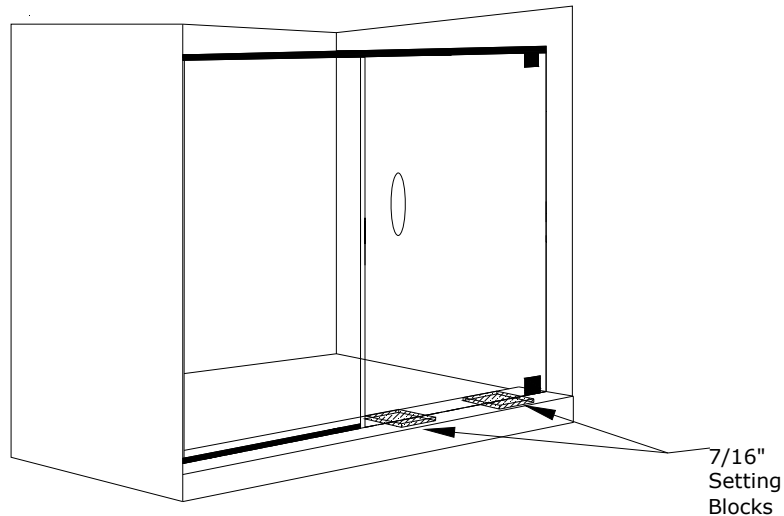

With the hinges in a closed position, lift the door into the shower top first then down onto the setting blocks. Slowly push the door fully up against the top and bottom hinge. Check the alignment around door. Gaps should be even and consistent. Align the door, then, have an assistant hold the door in place with a glaziers suction cup. After everything is aligned, secure the top inside cover plate with the supplied machine screws. **Note: Always tighten machine screws by hand!** Use a #3 Phillips head screwdriver for this. When tightening the screws alternate from one screw to the other so the pressure is evenly applied to the inside cover plate. Repeat the above process on the bottom hinge.

Door Pull

- 1) Take the two stud head mounting screws and sleeve one clear washer on each screw. Next, insert the clear grommets into the holes in the door. From the outside of the door, push the thread of the screws through the grommets in the holes in the glass. On the inside of the door, sleeve a clear washer onto the screws.
- 2) Take the pull that has the threaded hole in the end and begin to thread the top screw into it and then the bottom screw. Tighten the stud head screws down with a screwdriver (not a drill). This pull will be on the inside of the door.

3) Place the remaining pull, with the large holes and set screw, onto the stud heads of the screws. Tighten the set screws with Allen wrench provided.

Back To Back Pull

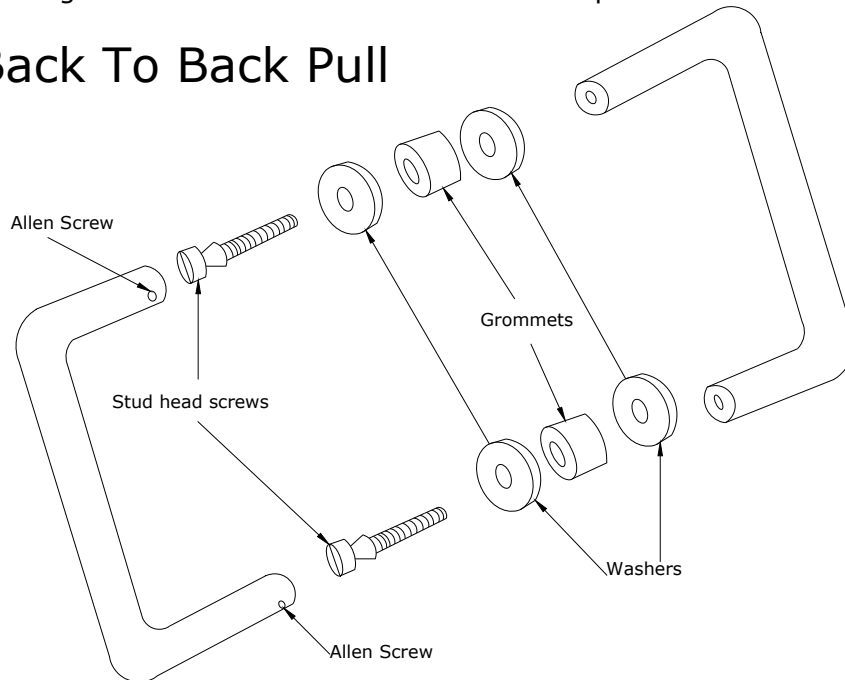

****When Applicable****

(in some applications there may not be room for seals and or sweeps)

Directions for SDTDF Double Fin, SDTJ-SDTB Bulb Seal, SDDTNL "L" Seal

When installing seals the glass edges should be clean and free from any dirt or hand oil etc... as these will prohibit adhesion. Glass cleaner will do.

Vertical seals will be applied to the edge of the glass using a VHB (very high bond) tape.

Apply VHB tape to edge of glass by adhering it top to bottom, gradually unrolling the tape as you slowly move from top to bottom. Apply the full length of glass. Cut flush

to the bottom of door glass.

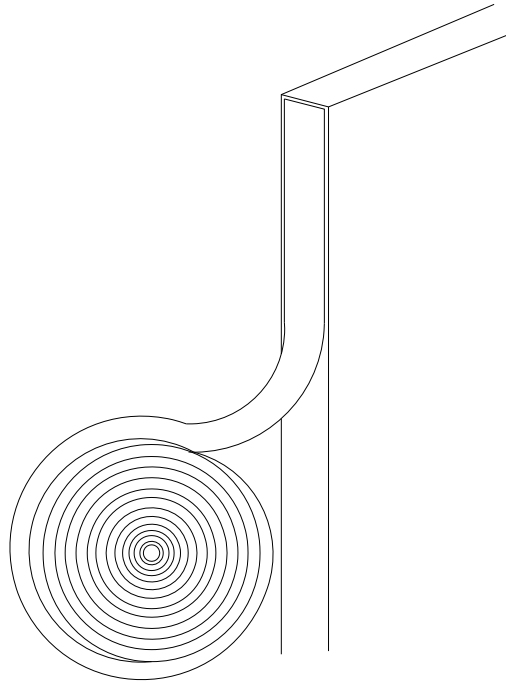

Then remove protective layer from other side and attach seal to the tape surface. Press on by hand. Cut flush to the bottom of the door using pliers-type cutter, scissors, or razor knife. The VHB tape will gain strength and achieve full bond within 72 hours.

Adjust door accordingly to achieve optimum seal.

Directions for P990WS

- 1) Measure and cut seal to appropriate size using miter saw or hacksaw.
- 2) Place over bottom edge of door. Then, using a plastic covered mallet, gently tap on bottom sweep until it is fully on. Make adjustments as needed.
- 3) Silicone ends and horizontal seams from glass to plastic.

Silicone Application

Once you confirm alignment of glass and everything is set, you need to apply a cap bead of clear 100% silicone around perimeter of u-channel edge where it meets the glass, both inside and out. Apply a small bead where u-channel meets installation surface, both inside and out. Finally apply a small bead from top to bottom in the inside corner of the butt joint.