

INSTALLATION INSTRUCTIONS

Model
CDM-90

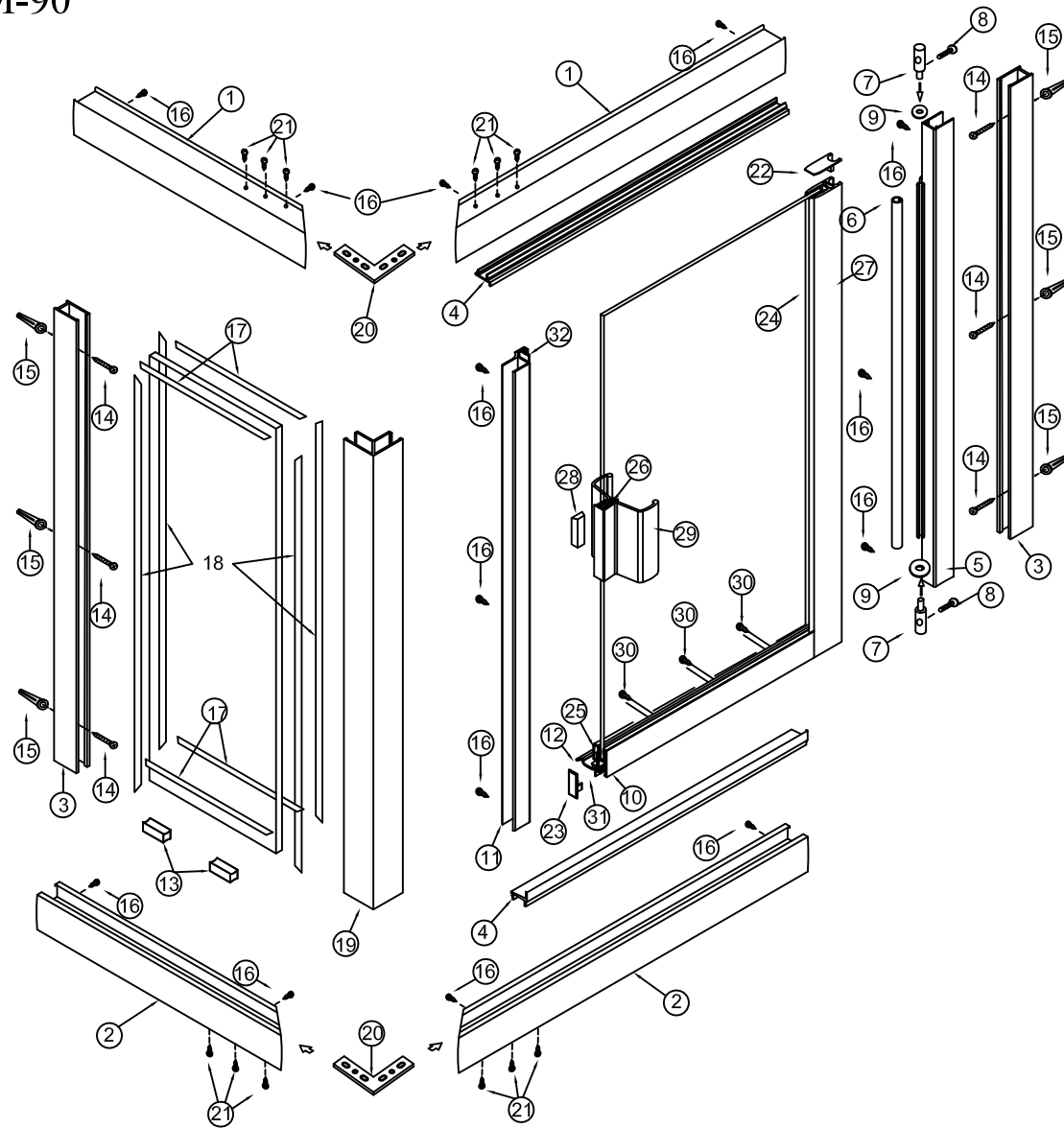

When ordering replacement parts, please provide the following information:

1. Part Number
2. Part Name
3. Model Number
4. Specify design (if any)

To install your Shower Enclosure you will need the following:

- Level
- 1/8" and 9/64" Drill Bits
- (Tile) 3/16" Masonary Bit
- Phillips Screwdriver
- Sealant
- Hack Saw

#	Description	Qty.	Part #	Picture
1	Header	2	ZSS-2101	
2	Curb	2	ZSS-2101	
3	Wall Jamb	2	ZD-1006	
4	Snap-In Filler	2	ZSS-1102	
5	Hinge Jamb	1	ZD-2505A	
6	Hinge Rail Sleeve	1	ZV-995	
7	Hinge Pins	2	ZV-910	
8	Hinge Pin Screw	2	#6-32x3/8" FH MS	
9	Washer	2	WS-516	
10	Bottom Rail	1	ZD-1002	
11	Latch Jamb	1	ZD-8004	
12	Drip Trough	1	ZD-2008	
13	Glass Setting Blocks	2	ZV-902	
14	Wall Jamb Inst. Screws	6	#8x1 1/2" PH SMS	
15	Wall Anchors	6	ZV-935	
16	Installation Screw	14	#6x3/8" PH SMS	
17	Horizontal Wedge Vinyl		ZV-906	
18	Vertical Wedge Vinyl		ZV-909	
19	90° Post	1	ZSS-1104	
20	Header/Curb Brackets	2	ZH-90	
21	Header/Curb Bracket Screws	12	8x1/4" FH "B"	
22	Top Cap	1	ZV-948	
23	Door Clip	1	ZV-940	
24	Hinge Rail- 3/16" Vinyl	ZV-925 3/16		
	Hinge Rail-1/4" Vinyl	ZV-925 1/4		
25	Bottom Rail-3/16" Vinyl	ZV-903		
	Bottom Rail-1/4" Vinyl	ZV-901		
26	Handle Gasket 3/16"	1	ZV-917	
	Handle Gasket 1/4"	1	ZV-916	
27	Hinge Rail	1	ZD-2503A	
28	Magnet	1	MAG-4013	
29	Door Handle Assembly	1	AZD-4011A	
30	#6X1/4" PH B-Point	3		
31	Drip Vinyl	1	ZV-934	
32	Strike Gasket	1	ZV-907	

Arizona Corporate Office
2801 W. Indian School Rd
Phoenix, AZ 85017
800-255-1901 PH
602-447-8208 FAX

Florida
8100-1 Westside Industrial Dr
Jacksonville, FL 32219
855-695-8899 PH
904-786-9025 FAX

Illinois
2601 Bond St #1
University Park, IL 60484
800-861-6120 PH
708-235-0729 FAX

Oregon
2057 Lars Way
Medford, OR 97501
866-773-7905 PH
541-773-7909 FAX

Colorado
5401 Oswego Street
Denver, CO 80239
866-574-1766 PH
303-574-1775 FAX

Utah
729 West 1700 South
Salt Lake City, UT 84101
877-402-5007 PH
801-972-3111 FAX

ARIZONA SHOWER DOOR

Tools you will need for this install

- ✓ Exploded View drawing of shower door
- ✓ 3/16" Masonry drill bit (use 9/64" drill bit for fiberglass)
- ✓ 1/8" drill bit
- ✓ Drill
- ✓ 4' Level
- ✓ Saw (Electric Chop saw or Hacksaw)
- ✓ #2 Phillips drill bit
- ✓ #2 Phillips screwdriver
- ✓ Tape Measure
- ✓ Pencil or Pen
- ✓ Caulking Gun
- ✓ 1-Tube of 100% Clear Silicone (no latex!)
- ✓ Vacuum Cleaner or Brush for clean up
- ✓ Glass Cleaner and Paper Towels
- ✓ Rubber Mallet
- ✓ File

Installation Instructions for Model CDM-90

Note: These instructions will refer to the item #'s in the Exploded View drawing. For example, #1, #2, #3 etc...
Please read through **all** of the instructions to get an over-view **before** you install the shower door.

1) Find the centerline of where the unit will be installed. This will usually be the center of the curb of the shower pan. Place a mark $1/2''$ inch to the outside of centerline at each end of the curb where it meets the wall and also at the corner **(A)**. This mark will represent the outside of the ZSS-2101 Curb (item #2 in exploded view). Use the centerline measurements that were given at the time of order to figure your ZSS-2101 sizes. Take the centerline measurement and add $1/2''$ to get the outside dimension of the ZSS-2101. Measure from the **outside** edge of the mitered corner, along the **outside** of the ZSS-2101 to the correct dimension and cut to size **(B)**. Repeat this procedure for the other ZSS-2101 Curb. Lay the curbs on a drop cloth or carpet to prevent from scratching them. Assemble the two pieces of curb on the floor using the ZH90 90 degree corner clip (#20) and the #8X $1/4''$ Header Curb Bracket Screws (#21). As the curbs are lying open end down, place the ZH90 clip onto the corner and align the miters, corner bracket, and holes. Fasten the corner together with the #8X $1/4''$ screws. Now place the assembled Curb pieces in the position laid out on the shower curb

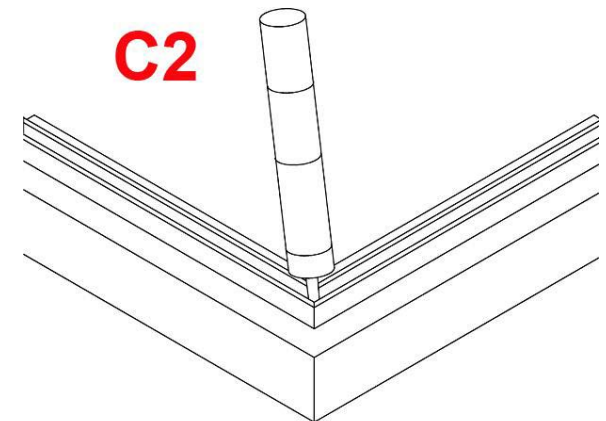
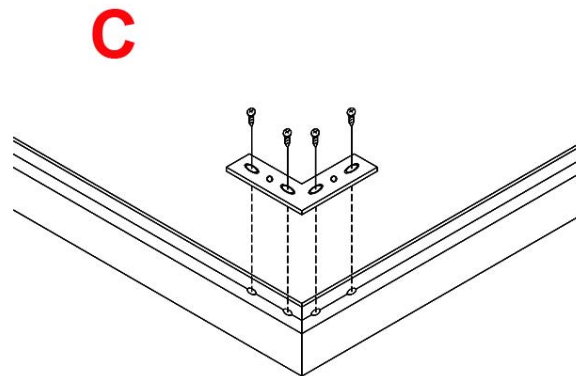
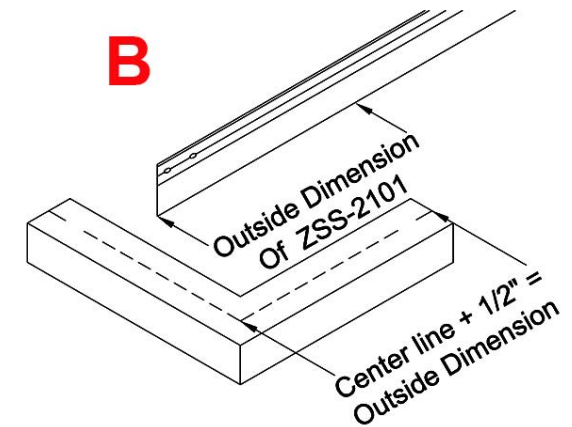
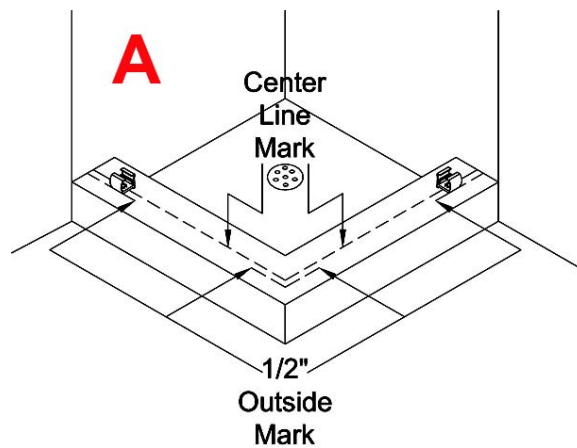

corresponding to the marks that you made. Make sure to fill the corner where the screws were inserted and ends with silicone so as to seal any gaps that might leak **(C)**.

2) Place a Wall Jamb ZD-1006 (#3) against the wall and down into the Curb. Use a level to position the jamb plumb, then mark the installation holes with a pen or pencil **(D)**. Repeat this procedure for the other jamb. Now drill the 6 holes with a 3/16" masonry bit (9/64" for fiberglass, & without anchors). Then insert the 6) ZV935 screw anchors (#15) in the holes. Fasten the ZD-1006 wall jambs in place using the #8X1-1/4 Phillips Pan Head screws provided (#14). Fill the corner with silicone on the inside of the ZSS-2101 to protect against water leaks **(E)**.

3) Place two Setting Blocks ZV902 (#13) into the Curb on the side where your panel will be. Insert the Glass into the ZSS-2101 Curb and the ZD-1006 Wall Jamb. Set your ZSS-1104 90° Degree Post (#19) down into the curb and over the edge of the glass **(F)**.

4) Plumb the ZSS-1104 Corner post then measure from the wall above the ZD-1006 wall jamb, over to the outside corner of the plumbed ZSS-1104. Add 1/4" to the measurement then cut the ZSS-2101. Follow the same procedure for the other header **(G)**. Assemble the two pieces of header on the floor using the ZH90 90 degree corner clip (#20) and the #8X1/4" Header Curb Bracket Screws (#21). As the headers are lying open end down, place the ZH90 clip onto the corner and align the miters, corner bracket, and holes. Fasten the corner together with the #8x1/4" screws (refer to **(C)**). Now place the

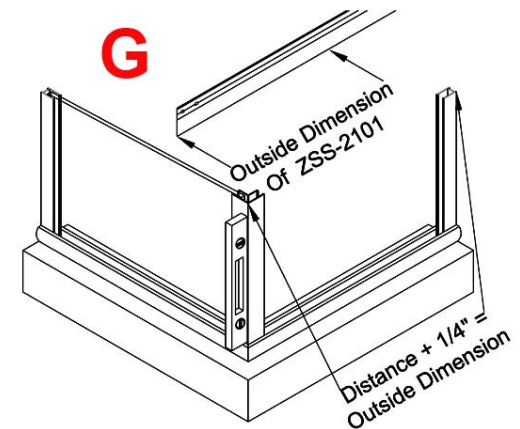
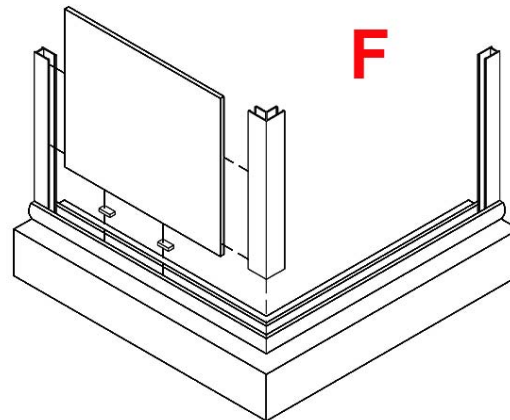
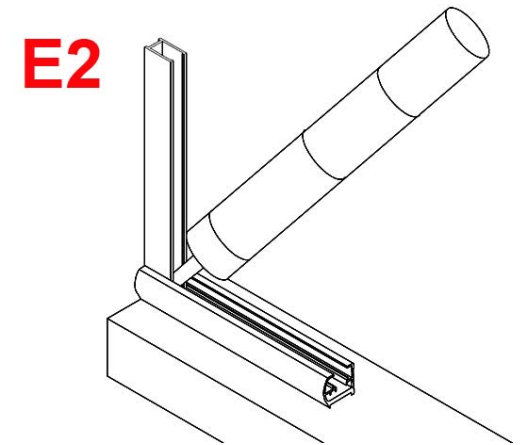
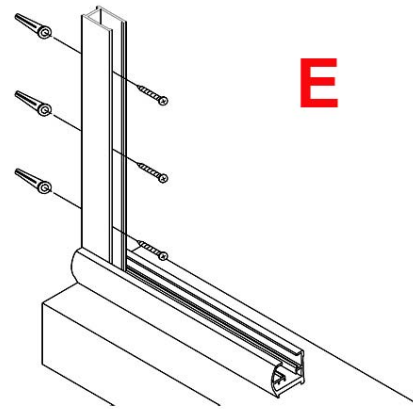
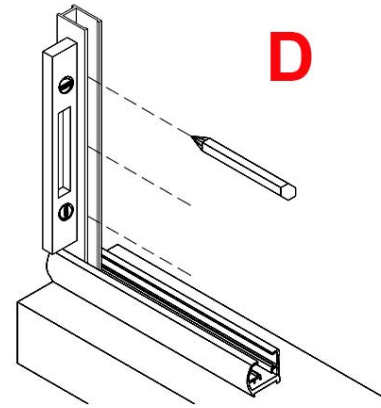

assembled header over and down onto the three vertical posts. Attach the Header to the Wall Jambs and Corner Post from the inside using a 1/8" drill bit to drill through the header and into the wall jambs and corner post. Secure with the #6X3/8" screws (#16) **(H)**. Insert the ZV909 Wedge Vinyl (#18) into the jambs on both sides of the glass. A block of wood will help push the vinyl in. Slightly wet the vinyl with water to ease install. The flat side goes against the glass. Notice the groove that will lock in to the edge of the wall jamb **(I)**. Insert the ZV906 Horizontal Wedge Vinyl (#17) in between the metal and glass without stretching it, both inside and out, top and bottom. Notice the locking groove **(J)**.

5) Now you need to cut the Snap In Fillers ZSS-1102 (#4). There are a number of ways to calculate the size of the ZSS-1102. This simple method will work for standard width as well as custom. Measure the overall width of the door. This is the outside edge of the ZD-2505A to the outside edge of the glass. Take that dimension and subtract 1/4" and that dimension will be your snap in size **(K)**. For example, if the overall width of the door is 29-3/4" then the snap in size is 29-1/2". Snap the fillers into the ZSS-2101's top and bottom. There is a small lip on the filler. This faces to the outside of the unit **(L)**.

6) Hang the door. Slide the ZD-8004 Magnetic Latch Jamb (#11) over the latch side wall jamb. Install the door by sliding the ZD-2505A Door Hinge Jamb (#5) over the hinge side wall jamb. Do not fasten the door at this point **(M)**. **Note:** (It will be helpful to have an assistant at this point to adjust and hold the door in place from

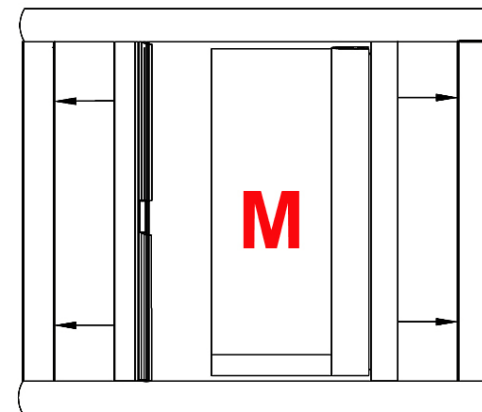
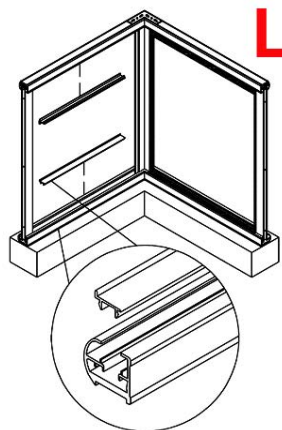
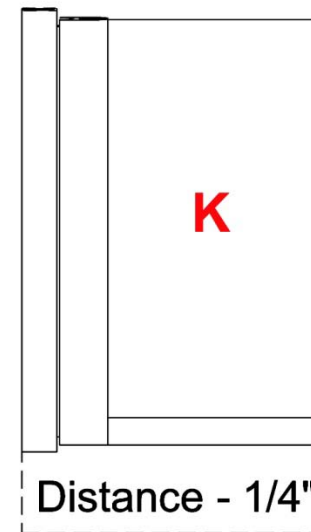
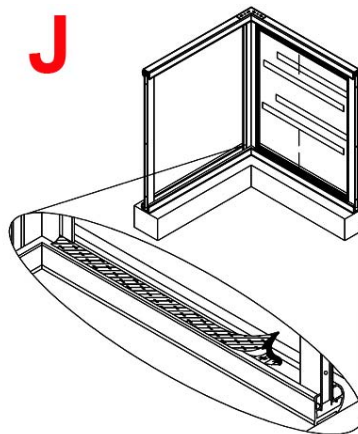
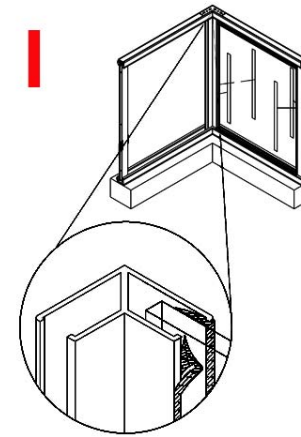
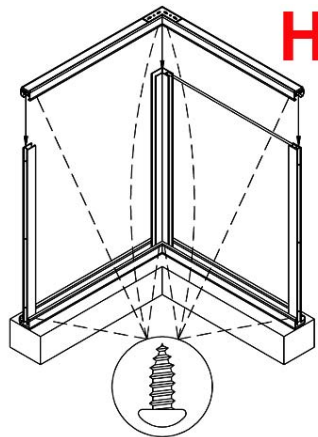

the outside while you drill and fasten the latch jamb and the hinge jamb from the inside). Square up the door and align the edge of the door glass parallel with the latch jamb leaving a 1/8" gap between the two. Attach the door by drilling the six holes on the inside of the unit where the jambs are pre-drilled using a 1/8" drill bit and secure with the 6-#6X3/8" Pan Head screws (#16) **(N)**

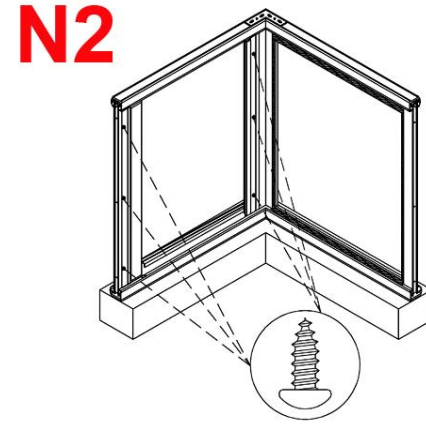
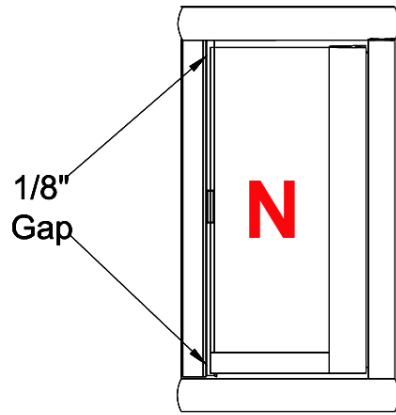

7) Attach the ZD-4011A Mag Handle (#27) to the door glass by placing the Handle Gasket (ZV 916 for 1/4" glass or ZV917 for 3/16" glass) (#24) over the edge of the glass then tapping the handle over the gasket and on to the glass with a rubber mallet aligning it to the magnet on the latch jamb **(O)**.

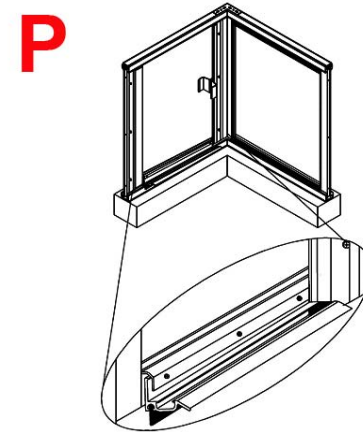
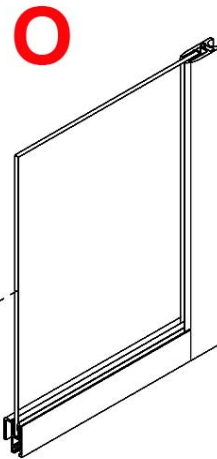

8) Adjust ZD-2008 Drip Trough (#12) on door to slope towards the hinge **(P)**.

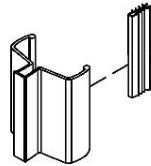

9) Run a bead of silicone on the gap between the metal and the shower surface inside and out around the entire unit. Fill all joints and gaps where metal meets metal and fill with a fine bead **(Q)**.

