

INSTALLATION INSTRUCTIONS

Model
LETE/LESE-I

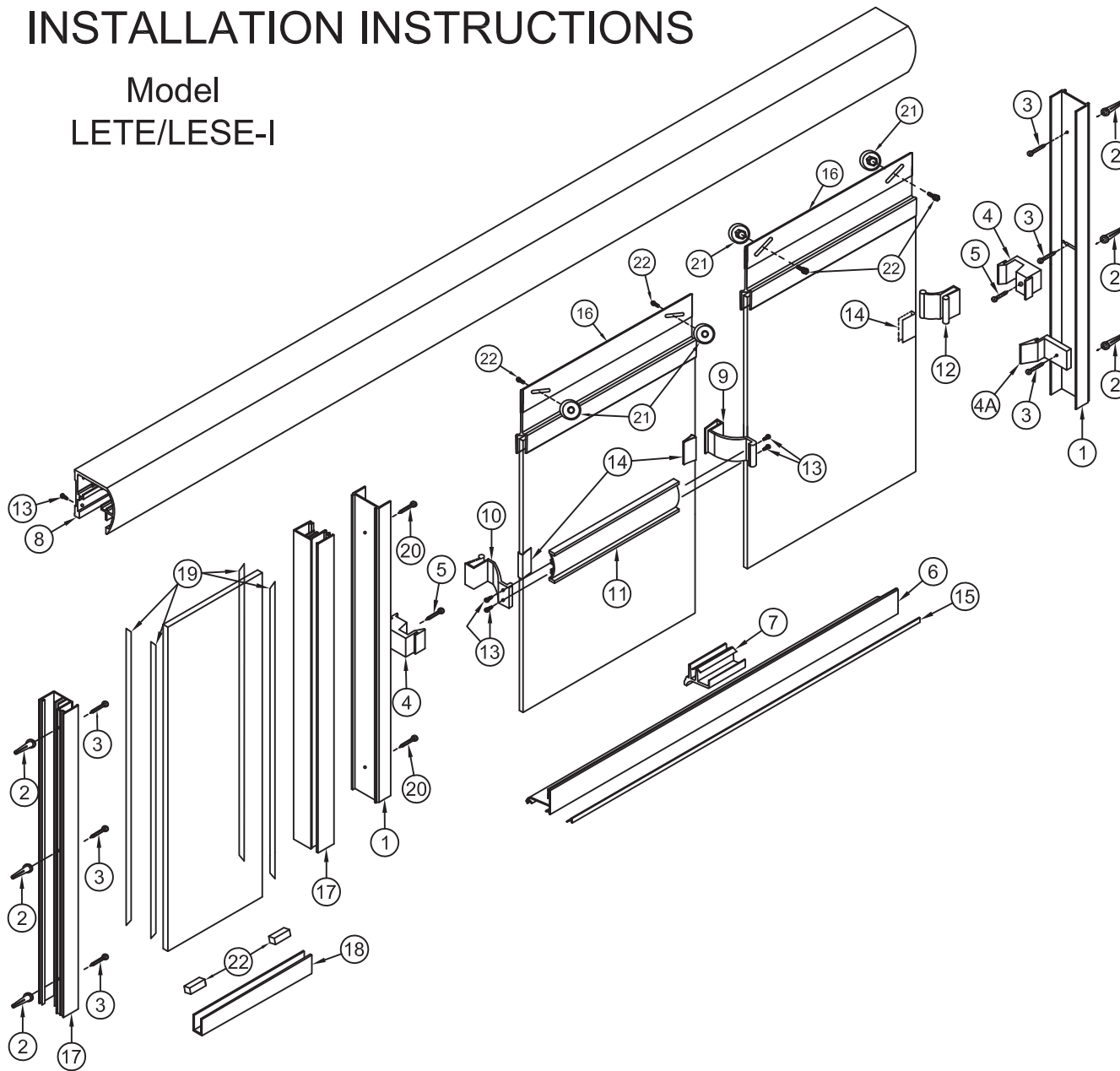

#	Description	Qty	Part #	Picture
1	Wall Jamb	2	ZTE-1203	
2	Screw Anchor	6	ZV-935	
3	#8x1 1/4 Pan Head Screw	6		
4	Bumper	2	ZV-924	
4A	Bottom Bumper	1	ZV-926	
5	#6/32 x1/2 Machine Screw	2		
6	Curb	1	ZTE-1222	
7	Center Guide	1	ZV920-3	
8	Header	1	ZTE-6201	
9	T-Bar Bracket	1	ZTE1206-1.5	
10	T-Bar Bracket W/Pull	1	ZTE1206P-1.5	
11	Towel Bar	1	ZTE-3205	
12	Pull Handle	1	ZTE-1207-1.5	
13	#6x3/8 Machine Screw	7		
14	Handle Vinyl	3	ZV-916	
15	Curb Vinyl	1	ZV-918	
16	Full Top Rail	2	ZTE-3208	
17	180 Jamb Post	2	ZTE-1216	
18	Buttress Curb	1	ZD-1014	
19	Vertical Wedge Vinyl	4	ZV-909	
20	#8x1 Pan Head Screw	3		
21	Roller Wheel	4	ZA-99	
20	#8/32x3/8 CH	4		
22	Setting Block	2	ZV-902	

When ordering replacement parts, please provide the following information:

1. Part Number
2. Part Name
3. Model Number
4. Specify design (if any)

To install your Shower Enclosure you will need the following:

- Level
- 1/8" and 9/64" Drill Bits
- (Tile) 3/16" Masonary Bit
- Phillips Screwdriver
- Sealant
- Hack Saw

Arizona Corporate Office
2801 W. Indian School Rd
Phoenix, AZ 85017
800-255-1901 PH
602-447-8208 FAX

Florida
8100-1 Westside Industrial Dr
Jacksonville, FL 32219
855-695-8899 PH
904-786-9025 FAX

Illinois
2601 Bond St #1
University Park, IL 60484
800-861-6120 PH
708-235-0729 FAX

Oregon
2057 Lars Way
Medford, OR 97501
866-773-7905 PH
541-773-7909 FAX

Colorado
3871 Revere Street
Denver, CO 80239
866-574-1766 PH
303-574-1775 FAX

Utah
2594 S. 3600 West Suite A
West Valley City, UT 84119
877-402-5007 PH
801-972-3111 FAX

ARIZONA SHOWER DOOR

Tools you will need for this install

- ✓ Exploded View drawing of shower door
- ✓ 3/16" Masonry drill bit (use 9/64" drill bit for fiberglass)
- ✓ 1/8" drill bit
- ✓ Drill
- ✓ 4' Level
- ✓ Saw (Electric Chop saw or Hacksaw)
- ✓ Side cutting pliers
- ✓ #2 Phillips drill bit
- ✓ #2 Phillips screwdriver
- ✓ Tape Measure
- ✓ Pencil or Pen
- ✓ Caulking Gun
- ✓ 1-Tube of 100% Clear Silicone (no latex!)
- ✓ Vacuum Cleaner or Brush for clean up
- ✓ Glass Cleaner and Paper Towels
- ✓ Rubber Mallet
- ✓ File

Installation Instructions for

Model LETE-I/LESE-I

Note: These instructions will refer to the item #'s in the Exploded View drawing. For example, #1, #2, #3 etc... Please read through **all** of the instructions to get an over-view **before** you install the door.

1) Typical placement for the shower door is in the center of the curb or tub ledge. Make marks on the curb/tub ledge to represent where the **outside** of the shower door will sit. Place the ZTE-1203 wall jamb (item #1 in exploded view) against the showerhead wall of the shower and on top of the ledge or curb aligning the outside edge of the jamb to the outside mark that was previously made **(A)**. Use a level to position the jamb plumb, then mark the installation holes with a pen or pencil **(B)**. **NOTE:** If you are installing on fiberglass you might have to file a radius on the backside of your jambs where the ledge/curb and the wall meet.

2) Now drill the 3 holes with a 3/16" masonry bit (9/64" regular bit for fiberglass, & without anchors). Then insert the 3)-ZV935 screw anchors (#2) in the holes. Fasten the ZTE1203 wall jambs in place using the #8X1-1/4 Phillips Pan Head screws provided (#3) **(C)**. **Important Note:** The ZV926 Bottom Bumper (#4A) needs to be installed with the bottom screw on the jamb, on

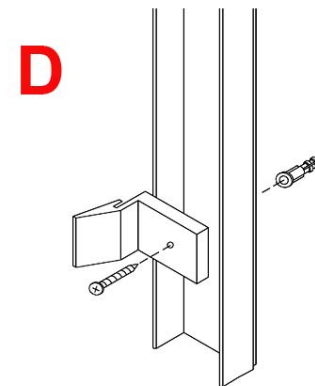
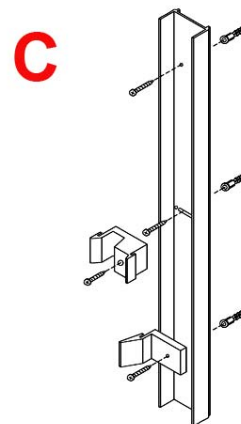
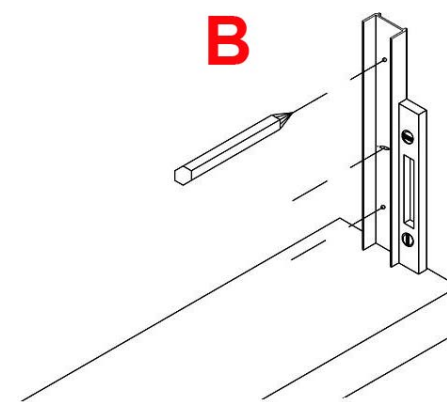
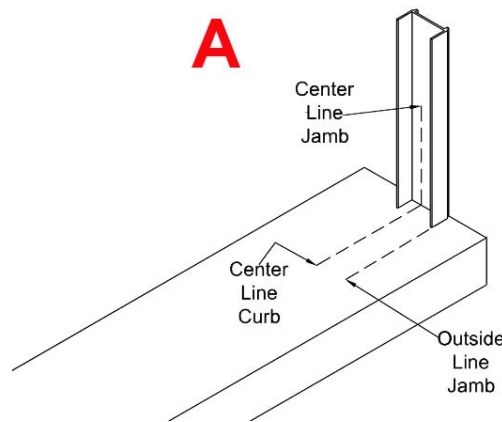

the showerhead side of the unit, with the angled side of the bumper going to the inside of the shower. Refer to the exploded view. Attach one of the ZV924 Bumpers (#4) using the #6/32X1/2 Machine screws (#5) keeping in mind that the inside panel will be on the showerhead side of the shower **(D)**.

3) Note: The glass pocket in the ZTE-1216 is offset to the outside. Place the ZTE-1216 180° Jamb Post (#18) against the opposite wall and on top of the ledge or curb aligning the outside edge of the post to the outside mark that was previously made. Use a level to position the jamb plumb, then mark the installation holes with a pen or pencil (**Note: Holes may need to be drilled in ZTE-1216 glass pocket**) **(E)**. Now drill the 3 holes with a 3/16" masonry bit. Then insert the 3)-ZV935 screw anchors (#2) in the holes. Fasten the ZTE-1216 180 Jamb Post in place using the #8X1-1/4 Phillips Pan Head screws provided **(F)**.

4) Cut the ZD-1014 Buttress Curb (#18) 1/2" wider than the inline panel of glass. This is the horizontal channel that holds the fixed panel **(G)**. Put a dab of silicone in the inside corner of the ZTE-1216 Wall Jamb then insert the ZD-1014 and push over into the ZTE-1216 aligning it to the outside marks that were made in step 1 **(H)**. **Note:** The ZD-1014 will be secured after the final step of running silicone at the end of

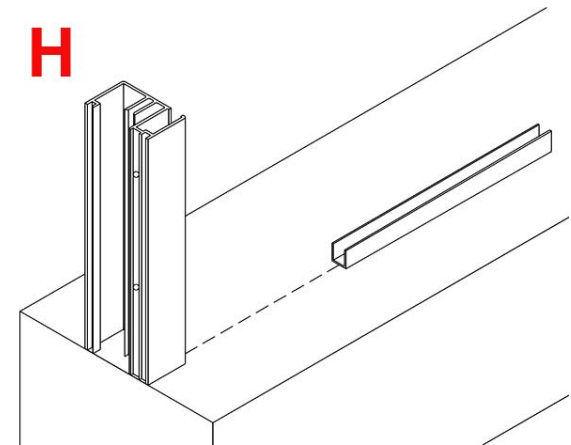
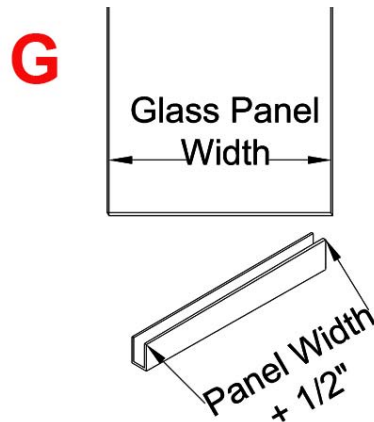
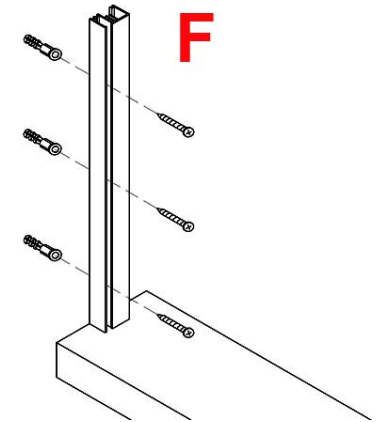
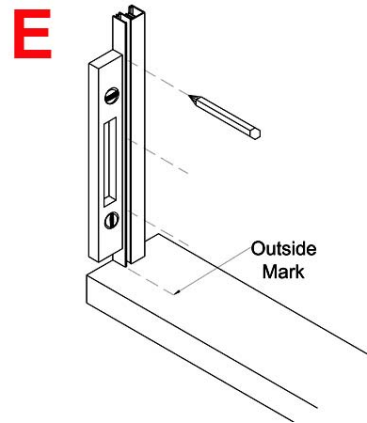

the install. When the silicone cures then the ZD-1014 will be solid.

5) Cut two setting blocks ZV-902 at 1/4" tall and insert them down into the bottom channel ZD-1014 for the glass to sit on. Then place the fixed panel into the wall jamb and down into the bottom channel until the bottom channel extends past the glass approximately 1/4" **(I)**. Attach the ZTE-1203 and the ZTE-1216 by screwing the two pieces together using the #8X1-1/4 Phillips Pan Head screws provided (#3) **(Note:** This may be a 1" screw depending on the model). Place the 180° Post which consists of the ZTE-1203 Wall Jamb and a ZTE-1216 180° Jamb Post over the edge of the glass **(J)**. Square the 180° post and Insert the ZV909 Wedge Vinyl (#19) into the vertical jambs on both sides. A block of wood will help push the vinyl in. Wet the vinyl slightly with water to ease install. The flat side goes against the glass. Make sure the panel is plumb **(K)**.

6) Measure the distance wall to wall above the jambs for the ZTE-6201 Header (#8) dimension. Cut to size. Place the header over and down on to the jambs **(L)**.

7) Measure the distance between the inside of the ZTE-1203 jambs (just above the tub ledge or curb). Measure tight and deduct 1/16" to 1/8" to get the cut size of the ZTE-1222 Curb (#6) **(M)**. Cut to size. Apply silicone where wall jambs meet tub or curb. Then run a bead along

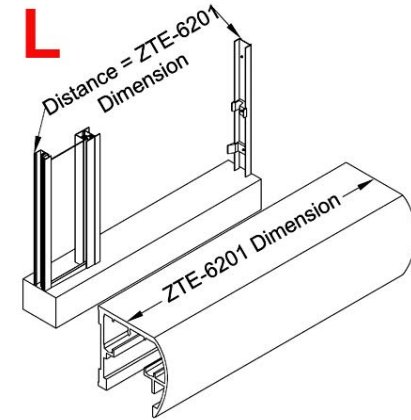
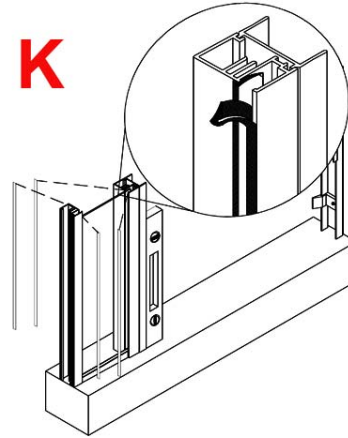
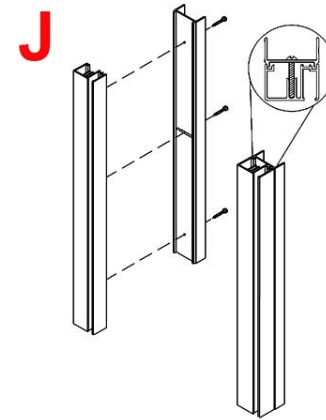
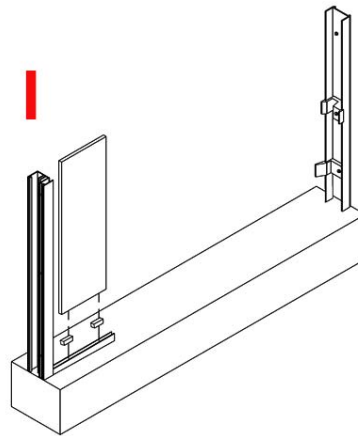

M

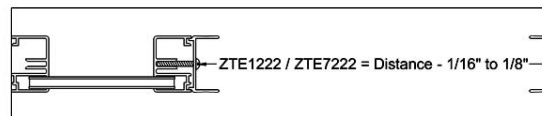

the underneath of the ZTE-1222 Curb (N). Slide the curb down between the wall jambs and onto the tub/shower. Make sure the curb is solid and doesn't rock back and forth. If it is not solid secure it with two of the #6X3/8" Pan Head Screws (#13) provided by drilling with a 1/8" drill bit through the outside leg of the wall jamb at the bottom, into the face of the curb and inserting the screws (O).

8) Plumb the 180° Jamb/Post (#9) and attach the header to the Jambs and Post from the inside of the shower using #6 x 3/8" Phil Pan Head Screws (#13). Attach the other ZV924 Bumper (#4) using the #6/32X1/2 Machine screw (#5) keeping in mind that the inside panel will be on the showerhead side of the shower (P).

9) Setting of the glass. The inside panel will be set first. This will be done as you stand on the **outside** of the shower. Grip one of the panels on each side so that the rollers are facing **away** from you. Lift the panel so that the bottom edge of the glass clears the top of the ZTE1222 Curb as you lower it into the shower. **Do not set the glass down on its edge. Be very careful to not hit the edge on anything.** Continue lowering the panel down until the top rollers can be guided up into the inside roller track of the header. Lift up glass then slowly lower the rollers into the inside roller track and let the panel hang in its vertical position. The outside panel will be installed the same way. Make sure the rollers are facing **toward** you. A helper would be valuable at this point to hold the inside panel on an angle toward the inside so the outside panel can be lowered and

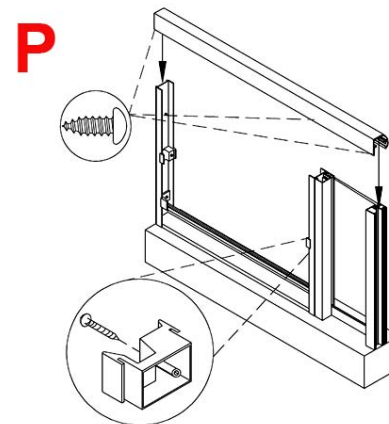
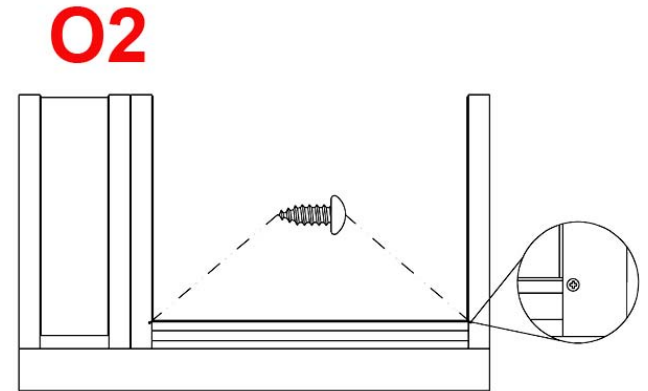
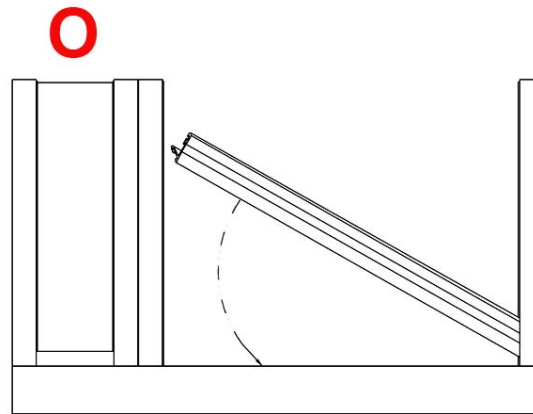
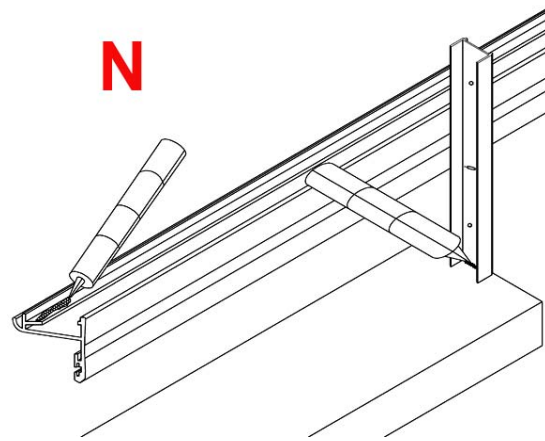

positioned to be installed into the outside roller track. The inside panel will be positioned at the showerhead side of the shower while the outside panel will be positioned opposite the showerhead. This is to ensure that no water escapes through the overlap **(Q)**.

10) Adjust Rollers. The roller wheels are mounted to angled slots in the top rail on the glass. Lowering the roller in the slot raises the glass. Raising the roller in the slot lowers the glass. Start out with the rollers mounted in the middle of the angled slot. If the panel needs to be adjusted you can remove the panel, adjust with a screwdriver then, reset the panel. This might be done one or two times until you achieve proper alignment. The end result should be that the vertical edge of the panel is parallel to your wall jamb to achieve maximum coverage **(R)**.

11) Attach the ZV920 Center Guide. Slide both panels to one end. The front lip of the guide slips into a race on the inside of the front edge of the ZTE1222 Curb. Position the guide just to the side of the panels, slip the front lip in, then snap the guide down over the inside of the curb. Slide the guide over carefully. When the doors are in a closed position the center guide should be centered in the overlap of the glass. For added security you can attach the guide after it is snapped in place by drilling with a 1/8" drill bit through the snap in leg into the curb(from the inside of the shower) then running a #6X3/8 screw into the hole **(S)**.

Q

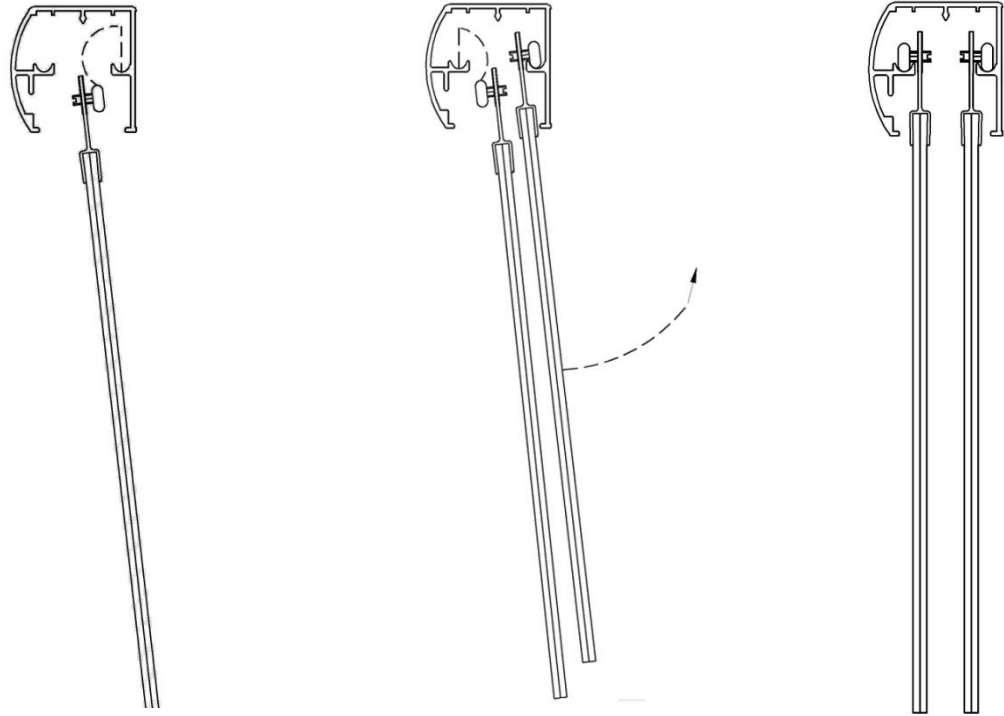

R



S

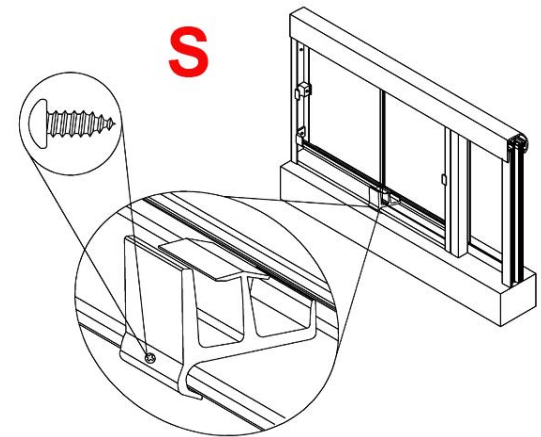

12) Attach the Handle ZTE1207-1.5 (#12) by placing the Handle Gasket ZV916 (#14) over the edge of the glass aligning it with the middle wall jamb bumper (ZV924) on the shower head side panel. Then place the handle over the gasket and gently tap onto the glass with a rubber mallet **(T)**.

13) Attach the Towel Bar using the ZTE1206-1.5 (#9) and the ZTE1206P-1.5 (#10) Brackets. Follow the same procedure as step 7 aligning the brackets with the middle wall jamb bumper. The 1206P will be used on the wall jamb side of the towel bar while the 1206 will go on the overlap side. After you attach the brackets slide the Towel Bar ZTE3205 (#11) into the brackets and secure with 4-#6X3/8 screws **(T)**.

14) Run a bead of silicone on the gap between the metal and the shower surface inside and out. Fill all joints and gaps where metal meets metal and fill with a fine bead. Run a bead also in the gap where the ZD-1014 and the glass meet **(U)**.

