

INSTALLATION INSTRUCTIONS

Model
LETE/LESE - 3

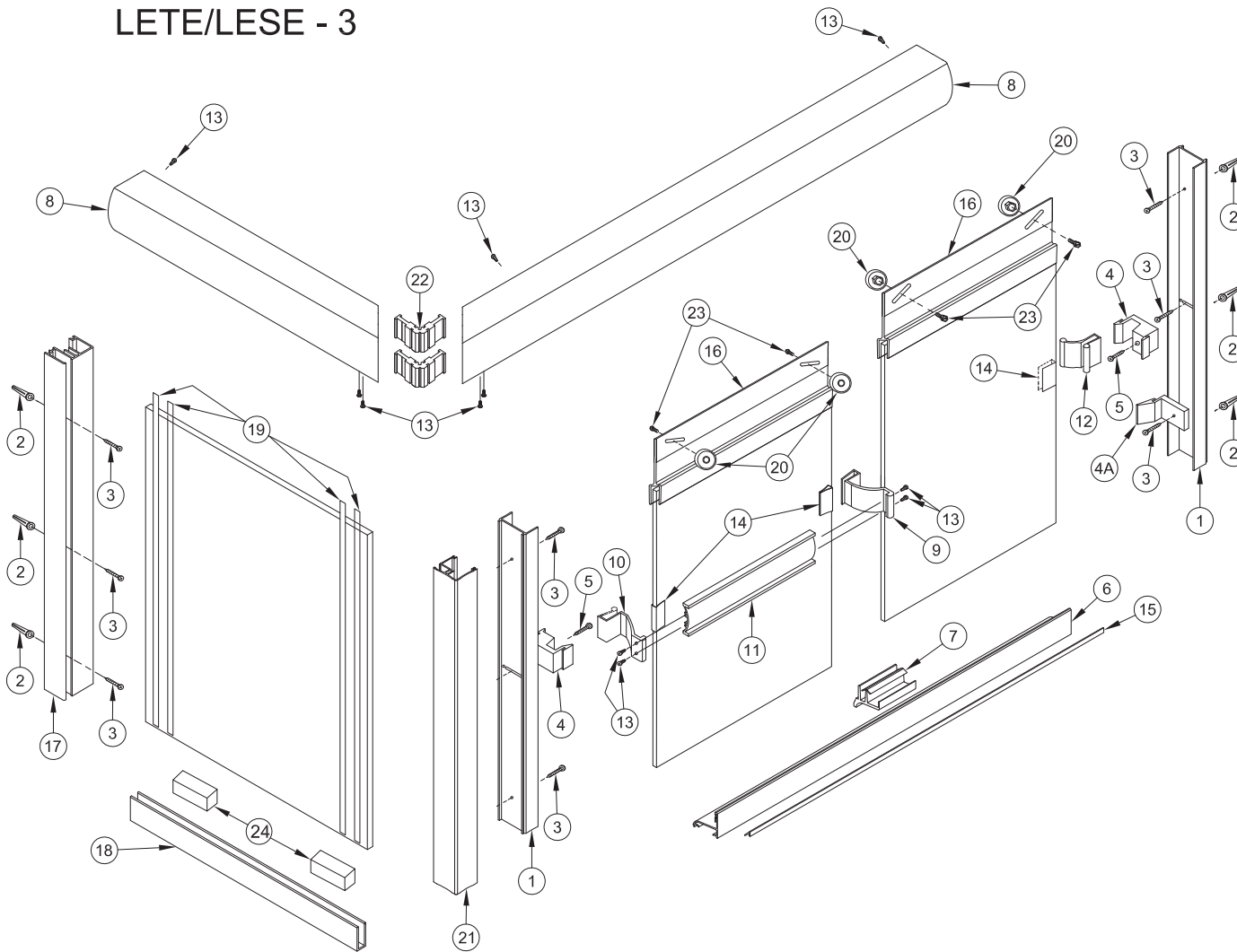

#	Description	Qty.	Part #	Picture
1	Wall Jamb	2	ZTE-1203	
2	Screw Anchor	6	ZV-935	
3	#8x1 1/4 Pan Head Screw	9		
4	Bumper	2	ZV-924	
4A	Bottom Bumper	1	ZV-926	
5	6/32 x1/2 Machine Screw	2		
6	Curb	1	ZTE-1222	
7	Center Guide	1	ZV-920-3	
8	Header	1	ZTE-6201	
9	T-Bar Bracket	1	ZTE-1206-1.5	
10	T-Bar Bracket W/Pull	1	ZTE-1206P-1.5	
11	Towel Bar	1	ZTE-3205	
12	Pull	1	ZTE-1207-1.5	
13	#6x3/8 PH SMS	11		
14	Handle Vinyl	3	ZV-916	
15	Curb Vinyl	1	ZV-918	
16	Full Top Rail	2	ZTE-3208	
17	180 Jamb Post	1	ZTE-1216	
18	Buttress Curb	1	ZD-1014	
19	Vertical Wedge Vinyl	4	ZV-909	
20	Roller Wheel	4	ZA-99	
21	90 Jamb Post	1	ZTE-1214	
22	Bypass 90 deg Header Clip	2	ZA90	
23	#8/32x3/8 CH	4		
24	Glass Setting Block	2	ZV-902	

When ordering replacement parts, please provide the following information:

1. Part Number
2. Part Name
3. Model Number
4. Specify design (if any)

To install your Shower Enclosure you will need the following:

- Level
- 1/8" and 9/64" Drill Bits
- (Tile) 3/16" Masonary Bit
- Phillips Screwdriver
- Sealant
- Hack Saw

Arizona Corporate Office
2801 W. Indian School Rd
Phoenix, AZ 85017
800-255-1901 PH
602-447-8208 FAX

Florida
8100-1 Westside Industrial Dr
Jacksonville, FL 32219
855-695-8899 PH
904-786-9025 FAX

Illinois
2601 Bond St #1
University Park, IL 60484
800-861-6120 PH
708-235-0729 FAX

Oregon
2057 Lars Way
Medford, OR 97501
866-773-7905 PH
541-773-7909 FAX

Colorado
3871 Revere Street
Denver, CO 80239
866-574-1766 PH
303-574-1775 FAX

Utah
2594 S. 3600 West Suite A
West Valley City, UT 84119
877-402-5007 PH
801-972-3111 FAX

ARIZONA SHOWER DOOR

Tools you will need for this install

- ✓ Exploded View drawing of shower door
- ✓ 3/16" Masonry drill bit (use 9/64" drill bit for fiberglass)
- ✓ 1/8" drill bit
- ✓ Drill
- ✓ 4' Level
- ✓ Saw (Electric Chop saw or Hacksaw)
- ✓ Side cutting pliers
- ✓ #2 Phillips drill bit
- ✓ #2 Phillips screwdriver
- ✓ Tape Measure
- ✓ Pencil or Pen
- ✓ Caulking Gun
- ✓ 1-Tube of 100% Clear Silicone (no latex!)
- ✓ Vacuum Cleaner or Brush for clean up
- ✓ Glass Cleaner and Paper Towels
- ✓ Rubber Mallet
- ✓ File

Installation Instructions for

Model LETE-3/LESE-3

Note: These instructions will refer to the item #'s in the Exploded View drawing. For example, #1, #2, #3 etc... Please read through **all** of the instructions to get an over-view **before** you install the door.

1) Typical placement for the shower door is in the center of the curb or tub ledge. Make marks on the curb/tub ledge 3/4" to the outside of centerline to represent where the **outside** of the shower door will sit. These marks should correspond with the dimensions the shower door was ordered to **Note: The glass pocket in the ZTE1216 is offset to the outside.** **(A)** Place the ZTE-1216 Wall Jamb (item #14 in exploded view) against the wall and on top of the tub ledge or curb on the fixed panel side aligning the outside edge of the jamb to the outside mark that was previously made. **(Note:** Holes may need to be drilled in ZTE-1216 glass pocket) Use a level to position the jamb plumb, then mark the installation holes with a pen or pencil. Follow the same procedure for setting the ZTE-1203 Wall Jamb (#1) on the showerhead wall **(B)**.

2) Now drill the 6 holes with a 3/16" masonry bit (9/64" regular bit for fiberglass, & without anchors). Insert the 6)-ZV935 screw anchors (#2) in the holes. Fasten the wall jambs in place

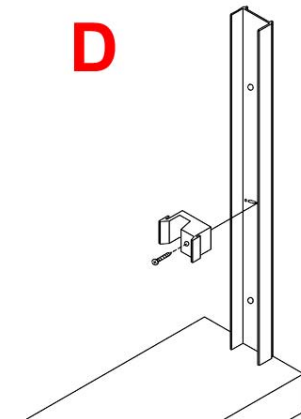
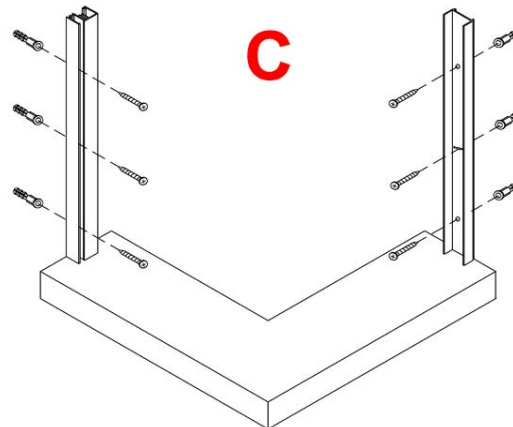
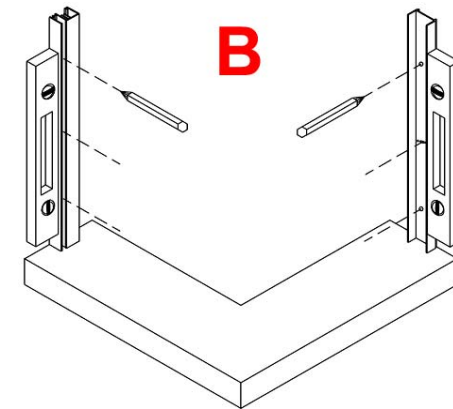
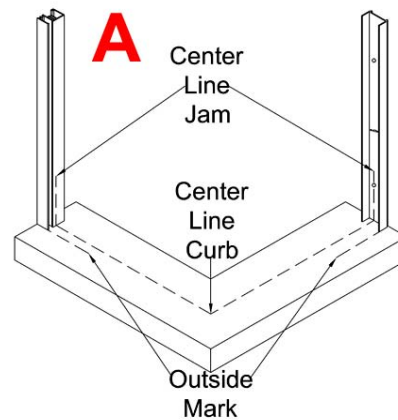

using the #8X1-1/4 Phillips Pan Head screws provided (#13) **(C)**. **Important Note:** The ZV926 Bottom Bumper (#4A) needs to be installed with the bottom screw on the ZTE-1203 Jamb, on the showerhead side of the unit, with the angled side of the bumper going to the inside of the shower. Refer to the exploded view. Attach one ZV924 Bumper (#4) on the ZTE-1203 using the #6/32X1/2 Machine screw (#5) keeping in mind that the inside panel will be on the showerhead side of the shower **(D)**.

3) Cut the ZD-1014 Buttress Curb (#18) 1/2" wider than the return glass panel dimension. This is the bottom channel that holds the fixed panel **(E)**. Put a dab of silicone in the inside corner of the ZTE-1216 Wall Jamb then insert the ZD-1014 and push over into the ZTE-1216 aligning it to the outside marks that were made in step 1 **(F)**. **Note:** The ZD-1014 will be secured after the final step of applying silicone at the end of the install. When the silicone cures then the ZD-1014 will be solid.

4) Cut two ZV902 setting blocks at 1/4" tall and insert them down into the ZD-1014 for the glass to sit on. Then place the fixed panel into the wall jamb and down into the bottom channel. Place the glass where the channel extends past the glass approximately 1/4" **(G)**. Attach the ZTE-1203 and the ZTE-1214 by screwing the two pieces together using the #8X1-1/4 Phillips Pan Head screws provided (#3) **(Note:** This may be a

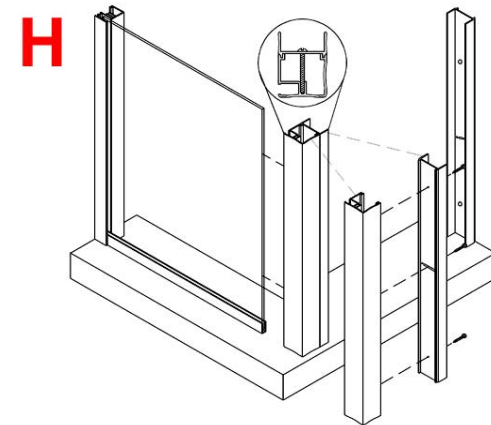
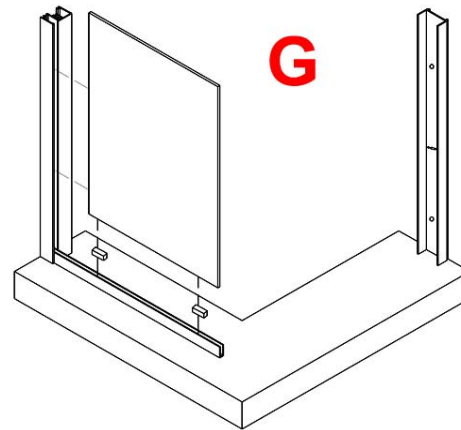
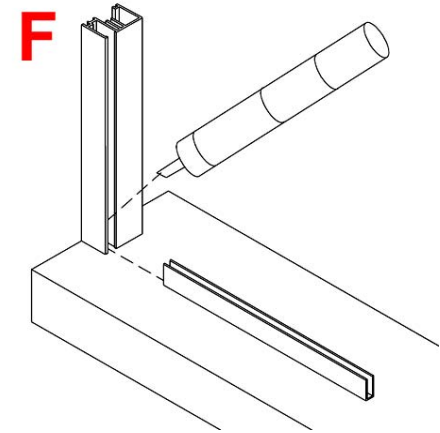
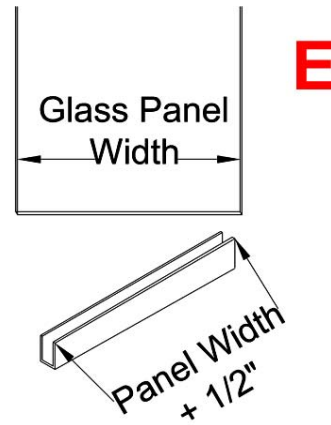

1" screw depending on the model). Place the 90 Post which consists of a ZTE-1203 Wall Jamb (#1) and a ZTE-1214 90 Jamb Post (#20) attached together, over the edge of the glass **(H)**. Adjust the 90° post to be plumb from both directions. Insert the ZV909 Wedge Vinyl (#19) into the jambs on both sides of the glass. A block of wood will help push the vinyl in. Slightly wet the vinyl with water to ease install. The flat side goes against the glass **(I)**.

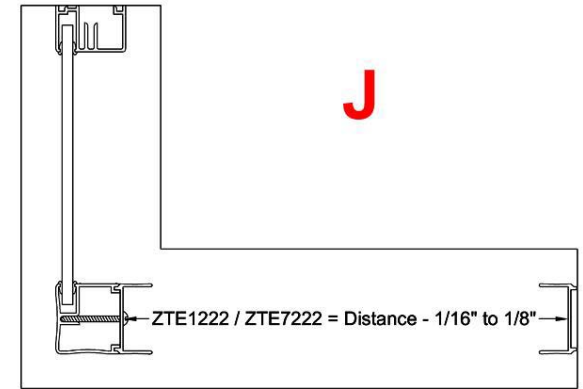
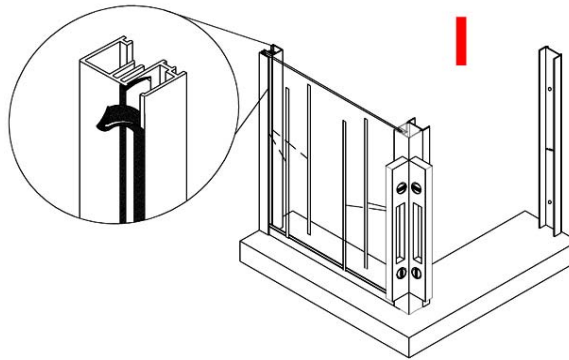

5) Measure for the ZTE-1222 (#6) by measuring the distance between the inside of the two ZTE-1203 Jambs then cut the ZTE-1222 (#6) to that dimension – 1/16" **(J)**. Run some silicone on the inside of the ZTE-1203's where they meet the curb/tub ledge. Then run a bead along the underneath of the ZTE-1222 Curb **(K)**. Slide the curb down between the wall jambs and onto the tub/shower. Make sure the curb is solid and doesn't rock back and forth. Secure it with two of the #6X3/8" Pan Head Screws (#13) provided by drilling with a 1/8" drill bit through the outside legs of the ZTE-1203 wall jambs at the bottom, into the face of the curb and inserting the screws **(L)**.

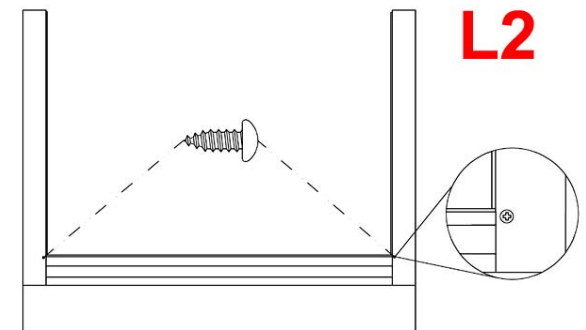
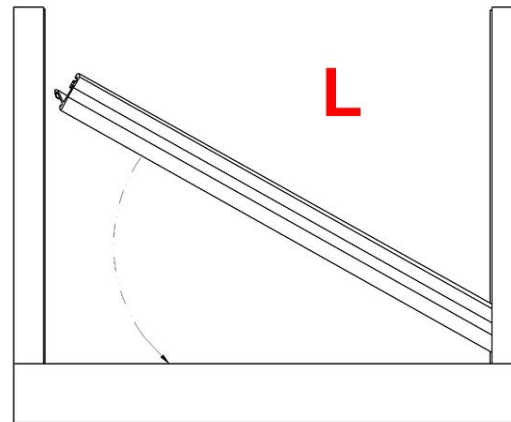
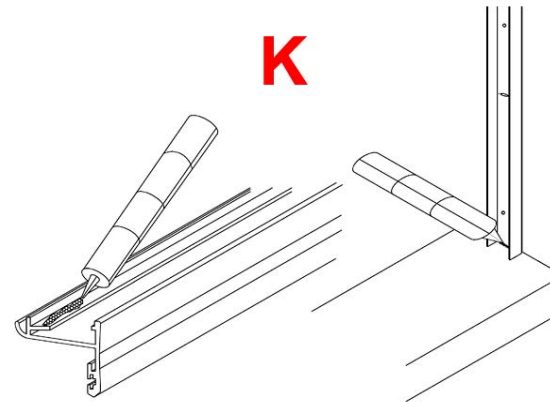

6) Measure for the ZTE-6201 two piece header (#8). Measure from the top of each wall jamb over to the outside corner of the plumb corner post. Add 1/4" to each of these measurements. These will be the dimensions that you will cut

each header to. Use a tape measure to mark the headers from the outside edge of the mitered corner. Cut the header **(M)**. Lay the headers on drop cloth or carpet to prevent from scratching them. Assemble the two pieces of header on the floor using the ZA90 90 degree corner clips (#21) and the #6X3/8" Phillips Pan Head screws (#13). Insert the ZA90 clips into the slots in the mitered end the headers then put the corner together. As the headers lay upside down on their topside, on the floor, drill with a 1/8" drill bit through the pre-drilled holes in the roller track where you have inserted the ZA90 clips. Make sure you drill deep enough so as to not break the head of the screw off. Slowly screw the #6X3/8" screw in **(N)**. If the screw does not want to go all the way in then remove the screw and if necessary ream the hole out slightly with the drill bit. Once all 4 screws are in then set the assembled header over and onto the two wall jambs and the corner post. Secure the header in three locations by drilling with a 1/8" bit through the inside face of the header and into the three vertical posts. Fasten with the #6X3/8" screws **(O)**.

7) Setting of the glass. The inside panel will be set first. This will be done as you stand on the **outside** of the shower. Grip one of the panels on each side so that the rollers are facing **away** from you. Lift the panel so that the bottom edge of the glass clears the top of the ZTE-1222 Curb as you lower it into the shower. **Do not set the glass down on its edge. Be very careful to**

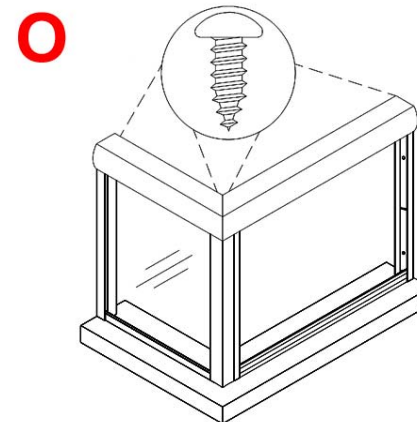
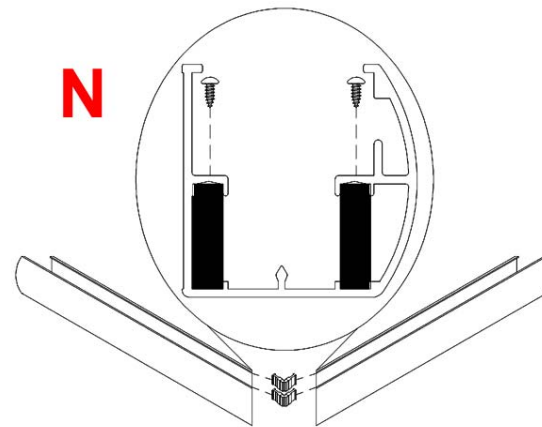
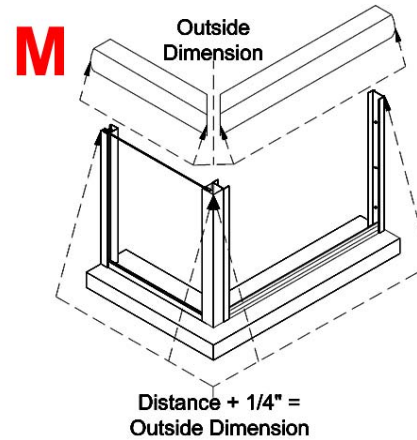

not hit the edge on anything. Continue lowering the panel down until the top rollers can be guided up into the inside roller track of the header. Lift up the glass, then slowly lower the rollers into the inside track and let the panel hang in its vertical position. The outside panel will be installed the same way. Make sure the rollers are facing **toward** you. A helper would be valuable at this point to hold the inside panel on an angle toward the inside so the outside panel can be lowered and positioned to be installed into the outside roller track. After both panels are installed the inside panel will be positioned at the showerhead side of the shower while the outside panel will be positioned opposite the showerhead. This is to ensure that no water escapes through the overlap **(P)**.

P

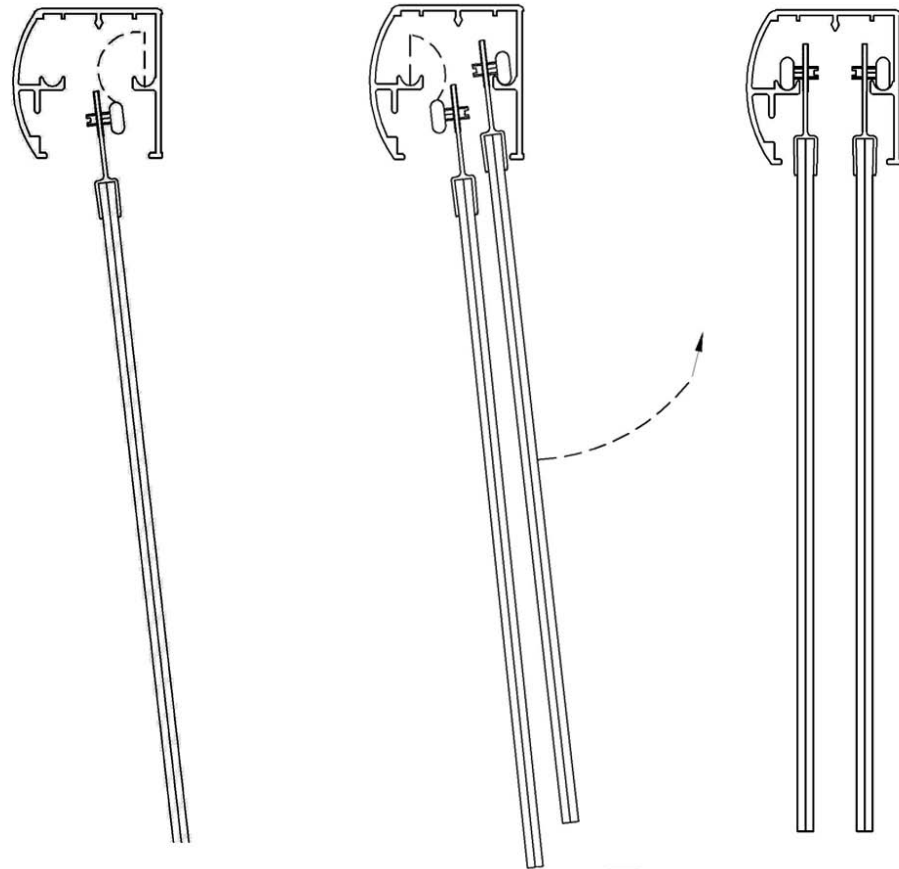

8) Adjust Rollers. The roller wheels are mounted to angled slots in the top rail on the glass. Lowering the roller in the slot raises the glass. Raising the roller in the slot lowers the glass. Start out with the rollers mounted in the middle of the angled slot. If the panel needs to be adjusted you can remove the panel, adjust with a screwdriver then, reset the panel. This might be done one or two times until you achieve proper alignment. The end result should be that the vertical edge of the panel is parallel to your wall jamb to achieve maximum coverage **(Q)**.

Q

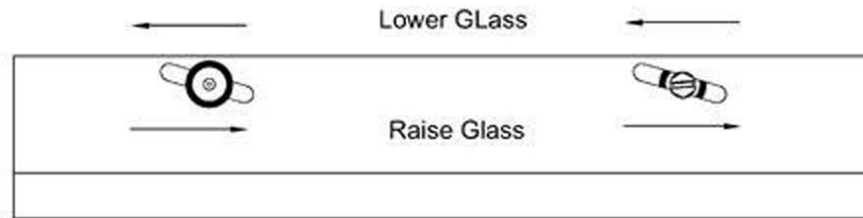

9) Attach the ZV920 Center Guide (#7). Slide both panels to one end. The front lip of the guide slips into a slot on the inside of the front edge of the ZTE-1222 Curb. Position the guide

just to the side of the panels, slip the front lip in, then snap the guide down over the inside of the curb. Slide the guide over carefully. When the doors are in a closed position the center guide should be centered in the overlap of the glass. For added security you can attach the guide after it is snapped in place by drilling with a 1/8" drill bit through the snap in leg and into the curb (from the inside of the shower) then running a #6X3/8 screw into the hole **(R)**.

10) Attach the Handle ZTE1207-1.5 (#12) by placing the Handle Gasket ZV916 (#14) over the edge of the glass aligning it with the middle wall jamb bumper (ZV924) on the shower head side panel. Then place the handle over the gasket and gently tap onto the glass with a rubber mallet **(S)**.

11) Attach the Towel Bar using the ZTE-1206-1.5 (#9) and the ZTE-1206P-1.5 (#10) Brackets. Follow the same procedure as step 10 aligning the brackets with the middle wall jamb bumper. The 1206P will be used on the wall jamb side of the towel bar while the 1206 will go on the overlap side (the 1206 is flat while the 1206P has a rolled edge on it). After you attach the brackets slide the Towel Bar ZTE-3205 (#11) into the brackets and secure with 4-#6X3/8 screws **(S)**.

12) Run a bead of silicone on the gap between the metal and the shower surface inside and out around the entire unit. Fill all joints and gaps where metal meets metal and fill with a fine bead. Run a cap bead also in the gap where the ZD-1014 and the glass meet **(T)**.

