

# INSTALLATION INSTRUCTIONS

## Model TOMBSTONE SERIES

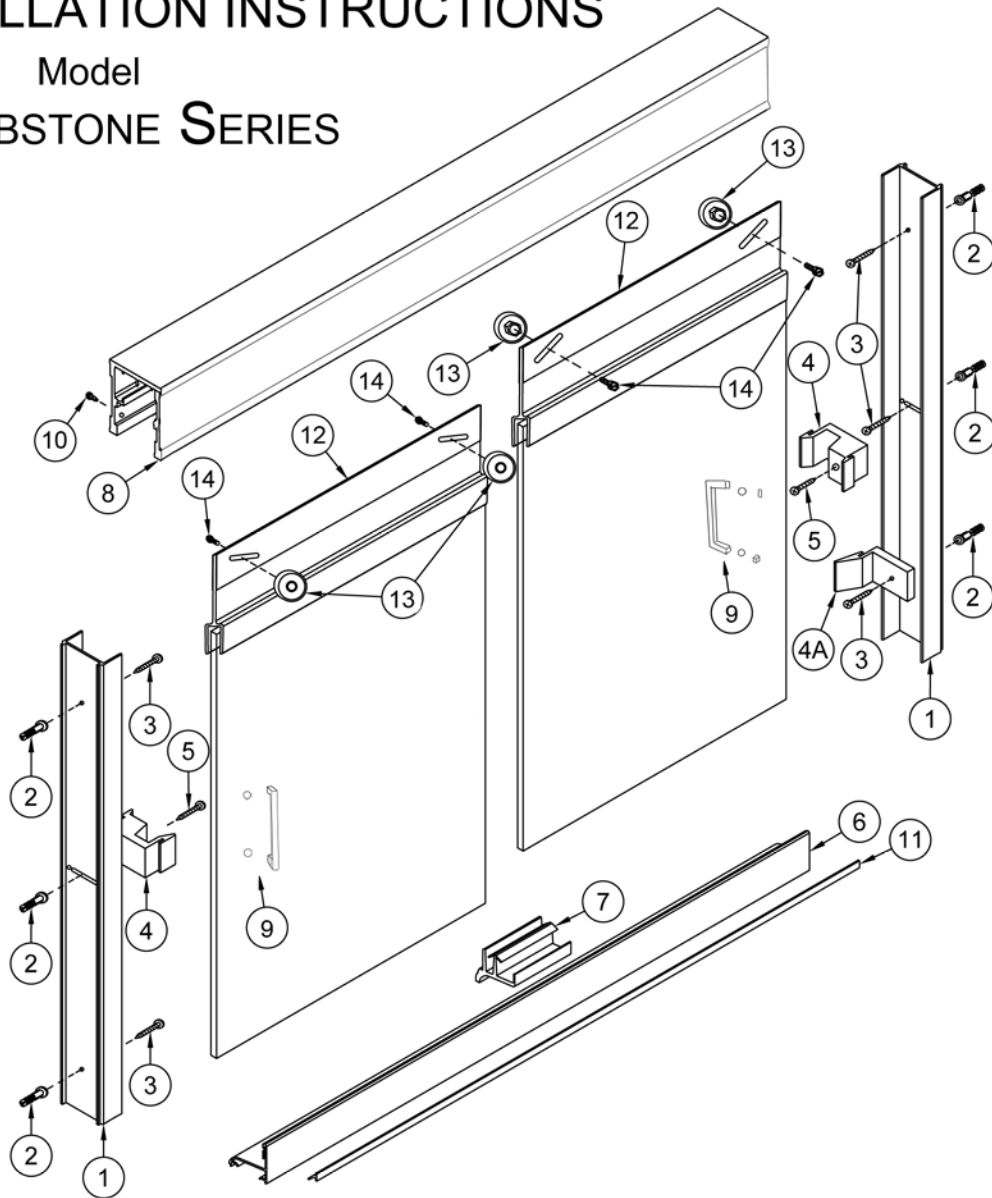

#	Description	Qty	Part #	Picture
1	Wall Jamb	2	ZTE-1203	
2	Screw Anchor	6	ZV-935	
3	#8X1 1/4 Pan Head Screw	6	F8X11/4	
4	Bumper	2	ZV-924	
4A	Bottom Bumper	1	ZV-926	
5	#6/32X1/2 Machine Screw	2	F6/32X1/2	
6	Curb	1	ZTE-1222	
7	Center Guide	1	ZV920-3	
8	Header	1	ZTE3601	
9	SINGLE SIDED PULL HANDLE	2	ASDSQ8	
10	#6X3/8 Pan Head Screw	2	F6X3/8	
11	Curb Vinyl	1	ZV-918	
12	Top Rail	1	ZTE3214	
13	Roller Wheel	4	ZA-99	
14	#8/32x3/8 CH	4	F8/32X3/8	

When ordering replacement parts, please provide the following information:

1. Part Number
2. Part Name
3. Model Number
4. Specify design (if any)

To install your Shower Enclosure you will need the following:

- Level
- 1/8" and 9/64" Drill Bits
- (Tile) 3/16" Masonary Bit
- Phillips Screwdriver
- Sealant
- Hack Saw

Arizona Corporate Office  
2801 W. Indian School Rd  
Phoenix, AZ 85017  
800-255-1901 PH  
602-447-8208 FAX

Florida  
8100-1 Westside Industrial Dr  
Jacksonville, FL 32219  
855-695-8899 PH  
904-786-9025 FAX

Illinois  
2601 Bond St #1  
University Park, IL 60484  
800-861-6120 PH  
708-235-0729 FAX

Oregon  
2057 Lars Way  
Medford, OR 97501  
866-773-7905 PH  
541-773-7909 FAX

Colorado  
3871 Revere Street  
Denver, CO 80239  
866-574-1766 PH  
303-574-1775 FAX

Utah  
2594 S. 3600 West Suite A  
West Valley City, UT 84119  
877-402-5007 PH  
801-972-3111 FAX

# ARIZONA SHOWER DOOR

## Tools you will need for this install

- ✓ Exploded View drawing of shower door
- ✓ 3/16" Masonry drill bit (use 9/64" drill bit for fiberglass)
- ✓ 1/8" drill bit
- ✓ Drill
- ✓ 4' Level
- ✓ Saw (Electric Chop saw or Hacksaw)
- ✓ Side cutting pliers
- ✓ #2 Phillips drill bit
- ✓ #2 Phillips screwdriver
- ✓ Tape Measure
- ✓ Pencil or Pen
- ✓ Caulking Gun
- ✓ 1-Tube of 100% Clear Silicone (no latex!)
- ✓ Vacuum Cleaner or Brush for clean up
- ✓ Glass Cleaner and Paper Towels
- ✓ Rubber Mallet
- ✓ File

INSTALLATION INSTRUCTIONS  
FOR

# MODEL TOMBSTONE – 1/4”

**Note:** These instructions will refer to the item #'s in the Exploded View drawing. For example, #1, #2, #3 etc...  
Please read through **all** of the instructions to get an over-view **before** you install the door.

**1)** Find the centerline of where the unit will be installed. This will usually be the center of the ledge of the bath tub or the curb of the shower pan. Place a centerline mark at each end of the tub ledge or curb where it meets the wall. This mark will also represent the center of the ZTE1203 wall jamb (item #1 in exploded view). Place the wall jamb against the wall and on top of the ledge or curb aligning centerline marks

**(A).** If your shower is fiberglass you might have to file the backside corner of the ZTE1203 to a radius so the jamb sits as flush as possible on the ledge or curb. Use a level to position the jamb plumb, then mark the installation holes

with a pen or pencil **(B)**. Repeat this procedure for the other jamb. Now drill the 6 holes with a 3/16” masonry bit (9/64” for fiberglass, & without anchors). Then insert the 6)-ZV935 screw anchors (#9) in the holes. Fasten the ZTE1203 wall jambs in place using the #8X1-1/4 Phillips Pan Head screws provided (#3) **(C)**.

**Important Note:** The ZV926 Bottom Bumper (#4A) needs to be installed with the bottom screw on the jamb, on the showerhead side of the unit, with the angled side of the bumper going to the inside of the shower **(D)**. Refer to the exploded view. Attach

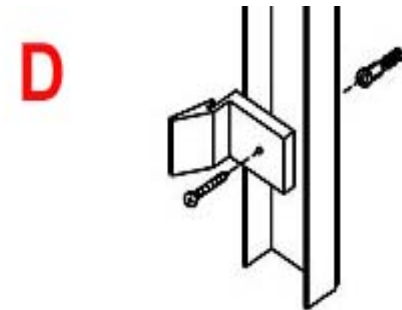
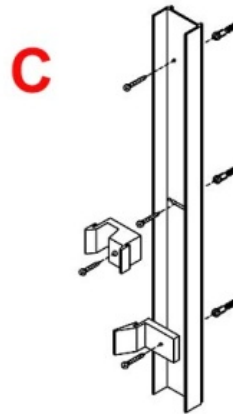
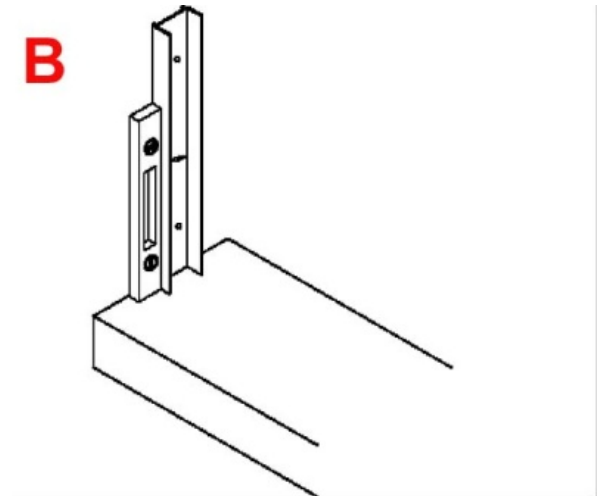
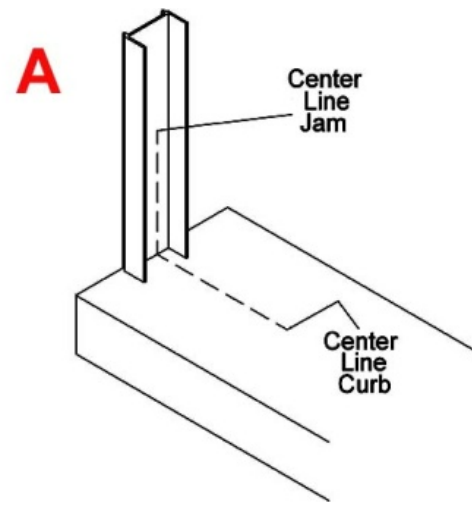

the ZV924 Bumpers (#4) using the 2-#6/32X1/2 Machine screws (#5) keeping in mind that the inside panel will be on the showerhead side of the shower.

**2)** Measure the distance between the inside of the wall jambs (just above the tub ledge or curb). Measure tight and deduct 1/16" to 1/8" to get the cut size of the ZTE1222 Curb (#6) **(E)**. Cut to size. Apply silicone where wall jambs meet tub or curb. Then run a bead along the underneath of the ZTE1222 Curb. **(F)** Slide the curb down between the wall jambs and onto the tub/shower. Make sure the curb is solid and doesn't rock back and forth. If it is not solid secure it with two of the #6X3/8" Pan Head Screws (#13) provided by drilling with a 1/8" drill bit through the outside leg of the wall jamb at the bottom, into the face of the curb and inserting the screws. **(G)**

**3)** Measure the distance from wall to wall across the top of the jambs. Cut the ZTE3601 Header (#8) to that dimension minus -1/16". Slide the header down over the top of the wall jambs. The header does not need to be secured with screws. **(H)**

**4)** Setting of the glass. The inside panel will be set first. This will be done as you stand on the **outside** of the shower. Grip one of the panels on each side so that the rollers are facing **away** from you. Lift the panel so that the bottom edge of the glass clears the top of the ZTE1222 Curb as you lower it into the shower. **Do not set the glass down on its edge. Be very careful to not hit the edge on anything.** Continue lowering the panel down

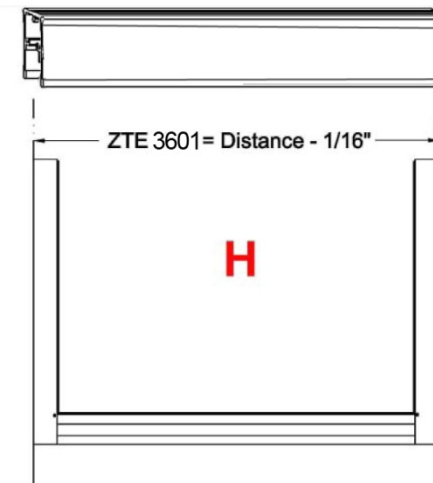
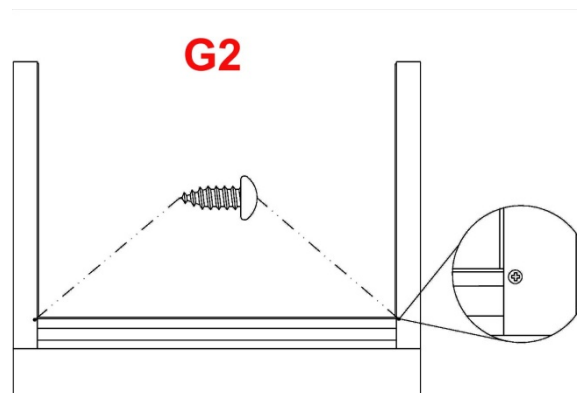
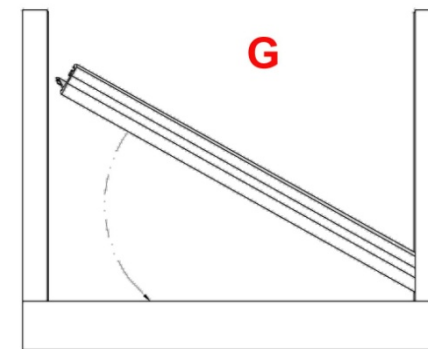
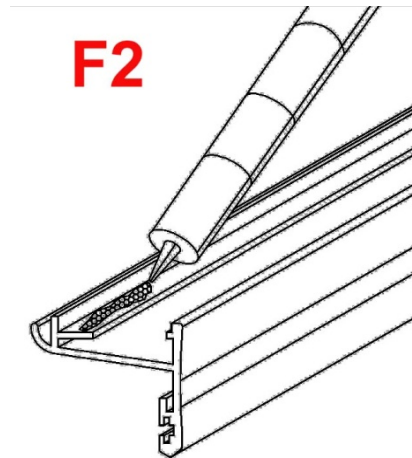
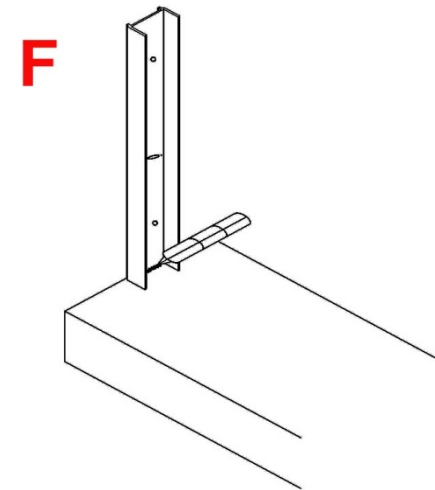
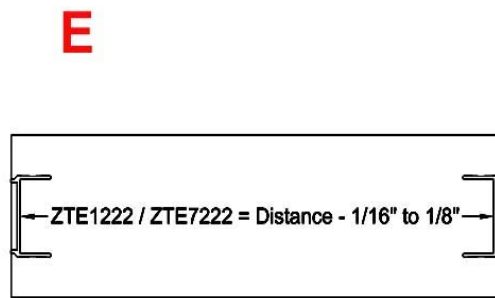

until the top rollers can be guided up into the inside roller track of the header. Lift up glass then slowly lower the rollers into the inside roller track and let the panel hang in its vertical position. The outside panel will be installed the same way. Make sure the rollers are facing **to-ward** you. A helper would be valuable at this point to hold the inside panel on an angle toward the inside so that the outside panel can be lowered and positioned to be installed into the outside roller track. The inside panel will be positioned at the showerhead side of the shower while the outside panel will be positioned opposite the showerhead. This is to ensure that no water escapes through the overlap. **(I)**

**5) Adjust Rollers. (J)** The roller wheels are mounted to angled slots in the top rail on the glass. Lowering the roller in the slot raises the glass. Raising the roller in the slot lowers the glass. Start out with the rollers mounted in the middle of the angled slot. If the panel needs to be adjusted you can remove the panel, adjust with a screwdriver then, reset the panel. This might be done one or two times until you achieve proper alignment. The end result should be that the vertical edge of the panel is parallel to your wall jamb to achieve maximum coverage.

**6) Attach the ZV920 Center Guide (#7).** Slide both panels to one end. The front lip of the guide slips into the slot on the inside of the

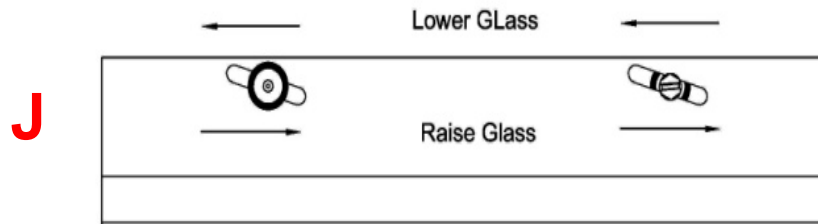
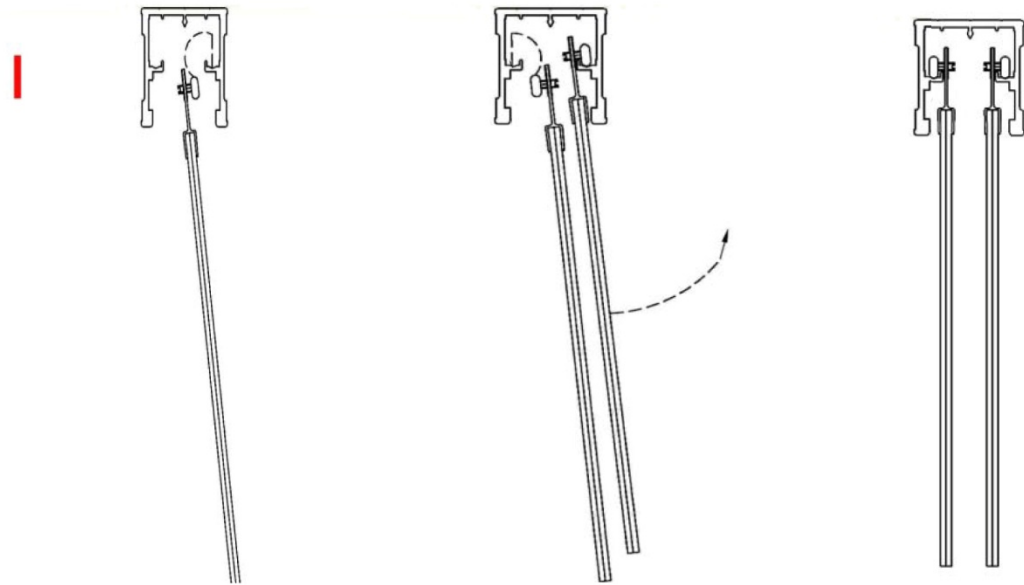

front edge of the ZTE1222 Curb. Position the guide just to the side of the panels, slip the front lip in, then snap the guide down over the inside of the curb. Slide the guide over carefully. When the doors are in a closed position the center guide should be centered in the overlap of the glass. **(K)** For added security you can attach the guide after it is snapped in place by drilling with a 1/8" drill bit through the snap in leg into the curb (from the inside of the shower) then running a #6X3/8 screw into the hole.

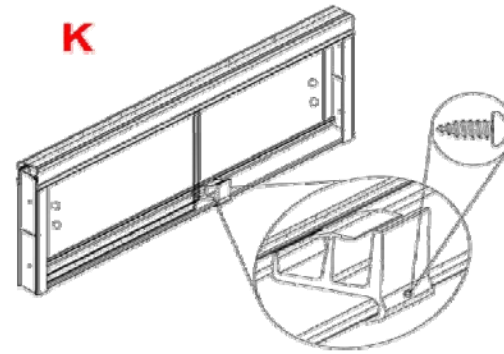

**7)** Attach one ASDSQ8 (#9) handle **(L)** by inserting the threaded bolt with grommet through the hole. This will be attached to the inside panel which will be on the showerhead side of the opening. The handle should be on the inside. Also make sure the plastic washers provided are on each side of the glass. Using a screwdriver tighten the bolt until the handle is secure. Over tightening can cause the glass to blow up. Next, attach the square cap over the bolt. Use the small Allen wrench provided to tighten the set screw to secure cap.

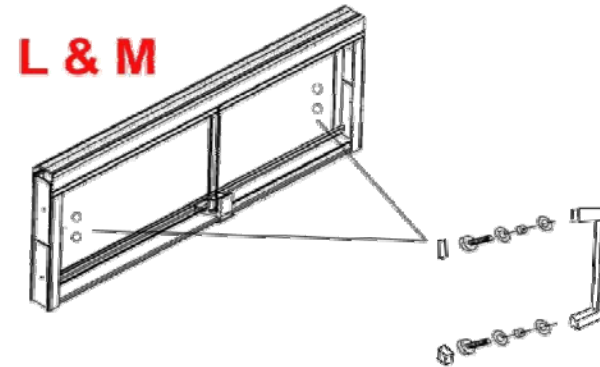

**8)** Attach the second ASDSQ8 (#9) handle **(M)** on the outside panel using the same method as in step 7. This handle should be on the outside of the unit opposite the showerhead.

**9)** Run a bead of silicone on the gap between the metal and the shower surface inside and out. Fill all joints and gaps where metal meets metal and fill with a fine bead. **(N)**

